

# General Specifications

GS 36J04A10-01E

NTPP001, NTPP002, NTPP003,  
NTPP004, NTPP005, NTPP006,  
NTPP007, NTPP008, NTPP009



Exaquantum Plant Information Management System

## ■ GENERAL

Exaquantum is a Plant Information Management System (PIMS) product that provides business benefits to users in the Hydrocarbons, Chemicals, Power & Utilities, Pulp & Paper and many other industries. The main function of Exaquantum is the acquisition of data from all facets of a business and the subsequent transformation of that data into easily usable, high-value, widely-distributed information. The data then becomes an integral part of the set of tools used by the business in vital decision-making processes.

Exaquantum supports rapid plant-related deployment, making the software easy to implement within plant-specific operational environments. This allows information to be structured sensibly around the production calendars and shift patterns in the plant.

Exaquantum is the business intelligent gateway between the operational Process Control System (PCS) and the business Enterprise Resource Planning (ERP) system. Using the latest, proven, Microsoft based open technology Exaquantum is designed to provide low administration costs, and be robust to future IT trends.

Exaquantum comprises the following features:

- Process Control Systems Interface
- Data processing and storage
- Role Based View of Exaquantum resources
- Visualization – Exaquantum/Explorer and Web UI
- Multiple server support
- Data exposure via APIs/OLE DB/OPC.

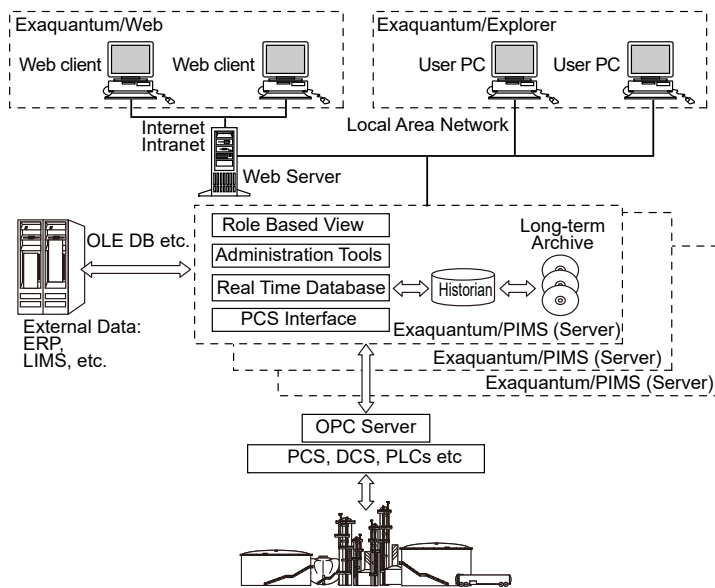

F01E.ai

Figure Exaquantum Overview

## ■ KEY FEATURES

### ● Process Control Systems Interface

Exaquantum primarily uses embedded OPC clients to access PCS data with the following OPC servers.

#### Data Access – OPC DA 2.05a compliant

- Yokogawa Exaopc for CENTUM VP, CS 3000, CENTUM CS, STARDOM and DARWIN.
- Yokogawa Exaopc-RD Redundancy package (\*1)
- Yokogawa FAST/TOOLS SCADA

#### Data Access – OPC UA DA compliant

- SMARTDAC+ (\*2)
- OPC UA Server (\*3)

---

**Alarms and Events Access – OPC A&E 1.1 compliant**

- Yokogawa Exaopc for CENTUM VP, CS 3000, CENTUM CS. (\*4)
- Yokogawa Exaopc-RD Redundancy package. (\*1)
- OPC A&E Servers from other suppliers.

**Historical Data Access – OPC HDA 1.1 compliant**

- Yokogawa Exaopc for CENTUM VP, CS 3000, CENTUM CS. (\*4)
- Yokogawa Exaopc-RD Redundancy package. (\*1)
- OPC HDA Servers from other suppliers.

**Text Files**

Import and export data in Exaquantum-defined ASCII format.

- \*1: When connecting Exaquantum to Exaopc-RD, please contact your Yokogawa representative.
- \*2: R3.10 or R3.15, SMARTDAC+ can only be available.
- \*3: R3.20 or later supported OPC UA server information, please contact your Yokogawa representative.
- \*4: CENTUM CS is supported by R3.20 or earlier.

● **Data Processing and Storage**

The Exaquantum Real Time Data Base (RTDB) provides tag-based, real-time process data to be utilized in various business application software. The data acquired to the RTDB can be optimized through the following functions:

• **Quality Codes**

Users can judge the validity and reliability of data at a glance. Exaquantum assigns quality codes to data that is transparent to data users. Quality Codes do not count as licensed tags.

• **Aggregations**

Basic statistical functions (minimum, maximum, mean, standard deviation, summations, differential summation and spot value) are calculated and stored using tag values over pre-defined (hour, day, month or user-defined) time periods. Aggregations do not count as licensed tags.

• **Custom Aggregations**

Users can query for aggregations over custom periods using the Exaquantum Excel Add-In or API.

• **Function Block**

Users can configure relational complex data processing groups as function blocks allowing easy and repeated use of data.

• **KPI Calculations**

Users can script simple or complex logic to create raw or aggregated values using calculated tags.

• **Exaopc HDA**

Following an Exaquantum shutdown period, Exaquantum can access Exaopc's (R2.10 or later) HDA server to retrieve missing process data (allowing aggregated and calculated values to also be generated) and Alarms & Events (A&E). After a LAN interruption, aggregation values can be recalculated. Exaquantum can access Exaopc's (R3.10 or later) HDA server to retrieve missing process data.

To enable Exaopc History Catch-up functionality, it is necessary to install Exaopc on a separate server to that used by Exaquantum. The specification of the Exaopc server must be suitable for History Catch-up to perform properly.

Exaquantum can also be used as a Data Historian to securely store large amounts of process data and Alarms & Events. Its powerful and fast storage and retrieval capabilities means there is virtually no limit to the amount of historical data that can be available online. Automatic archiving and deletion permits older data to be removed from the system, which can be restored later.

● **Role Based Name Space (RBNS)**

Exaquantum can be configured to provide each user with their own Microsoft Windows group-personalized folder hierarchy and naming convention view of Exaquantum process data when using the Exaquantum Data Selector within Exaquantum/Explorer, Exaquantum/Web or the Exaquantum Excel Add-In across all Exaquantum servers.

The Exaquantum administrator controls read and write access to Windows defined user groups. Read-only access allows process data to be viewed on displays by users. Write access allows users to write data to Exaquantum on a function block or tag basis.

● **Multiple Server Support**

Multiple Exaquantum servers can seamlessly integrate their process data together to allow visualization on a single display screen or report. For example, a display screen may consist of a textual tag field showing data from one Exaquantum server and a trend showing data from another Exaquantum server.

A Primary and Standby Exaquantum server is designated to contain the Role Based View information accessed by the users.

If Exaquantum calculation tags require inputs from tags located on other Exaquantum servers then this functionality (cross server calculations) is available by purchasing the Exaquantum Open Interface (NTPP007).

All Exaquantum servers must contain the same software revision.

● **User Interfaces**

Exaquantum provides the following user interfaces.

**Exaquantum/Explorer**

For users who need to create standard, pre-configured, fixed or ad-hoc display screens, the following Exaquantum/Explorer design tools are available:

- Graphics configuration and runtime support, with components such as Trends, X-Y Plots, Tubular Trends, Data Entry Grid, Data Write Back, Alarms and Events viewing, Excel Viewer and Web Browser.
- Advanced features such as Report Times, Scripting, Navigation and Data Parameterization.
- Excel Add-In for reporting and analysis of Exaquantum data.

Exaquantum/Explorer can be installed on a CENTUM HIS.

**Exaquantum/Web**

For people using Microsoft Internet Explorer Web technology deployed on either their PC or tablet and Apple Safari on tablet devices. In addition, users can select tags from a displayed graphic for displaying on a trend. Exaquantum/Web supports the following features.

- Plant graphics containing dynamic plant views created with the Exaquantum Web Graphics Editor, add in description of running ad-hoc trend from graphic or imported and converted Yokogawa DCS graphics.
- Simple to use Trending, with a maximum of 4 graphs per page, featuring:
  - Time range selection
  - Zoom and Trend Legend
- Users can create ad-hoc Trends which can be saved for subsequent re-use and shared with other users.
- Trends can display Alarms & Events for process data analysis.
- Users can add annotations (notes) to Trends to document plant data.
- Display pre-configured Word, Excel, PDF, etc. reports.
- Excel Add-In for reporting and analysis of Exaquantum data in the Web environment that is compatible with the Exaquantum/Explorer Excel Add-In.
- X-Y plots for data analysis.
- Trends and X-Y plots can be displayed via a URL.

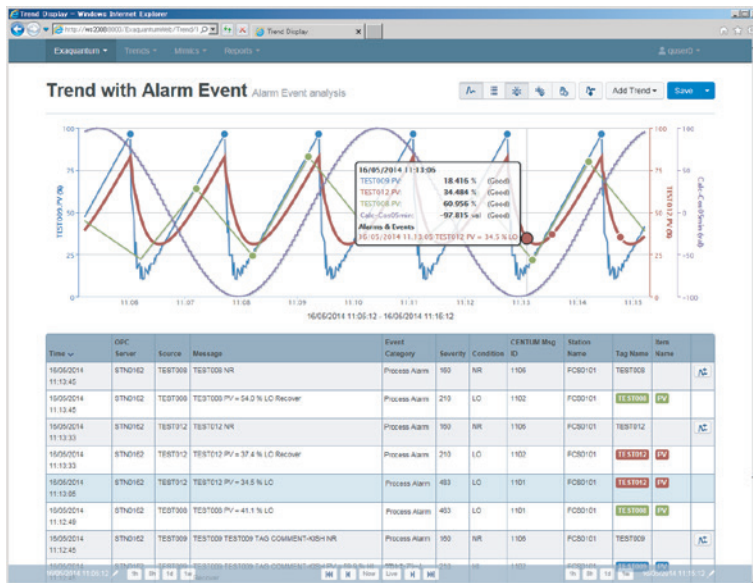

F02E.ai

Figure: Overlapped Trend with Alarms & Events

**Exaquantum Graphic Conversion Tool**

This tool converts imported CENTUM VP and CS 3000 graphics into Exaquantum/Explorer and Exaquantum/Web graphics.

● **Data Availability via OLE DB**

Exaquantum raw, aggregated and calculated values, along with A&E, can provide valuable information to third party application packages. The Exaquantum OLE DB interfaces can be used to access this information.

These two interfaces allow users to view a snapshot of Exaquantum data using minimal programming.

● **Data Access through OPC**

Application packages can access Exaquantum data via the Exaquantum OPC server, which supports OPC DA 2.05a and HDA 1.1.

---

## ● PI OPC Open Interface

Exaquantum process data and Alarms & Events can be provided to an OSIsoft PI historian using the Exaquantum OPC Server interface. Tag definition data can be exported from Exaquantum, using Excel or text files to configure the PI historian. PI must have an equal number of tags to map the Exaquantum data.

Note: The number of tags required for PI is the total of Exaquantum's instantaneous values and all the aggregation items.

Note: If the PI OPC Open Interface is required, please contact your local Yokogawa representative in advance of implementation as some configuration is required.

## ● History Data Export (HDE) Tool (R3.20 or later)

The History Data Export (HDE) tool extracts tag data from Exaquantum's Historian utilizing OPC HDA. The tool can be run as a command line tool or run displaying a User Interface.

## ■ BUSINESS BENEFITS

The business benefits of making information available are both diverse, and industry-specific. Some of the typical benefits are described below.

### ● Information Distribution

The availability of large amounts of data available on the desktops and tablets of many users increases efficiency. This increase is a result of fast and easy access to many different types of data. RBNS further increases efficiency, by presenting users with just the data that is pertinent to them. When Internet and Intranet access to data is also taken into account, the benefits are even more apparent.

### ● Enhancing PCS Data

Many data sources have limited scope for enhancing their own data. Exaquantum can enhance PCS data with a set of built-in aggregations. For example, users in some hydrocarbon industries will find one hour (or shift, daily, etc.) values (minimum, maximum, mean, summations, equipment run time, etc.) more useful than raw data, especially if totalizers or accumulators are used for flow measurements. Exaquantum can further enhance the raw and aggregated data with custom calculations.

### ● Enhancing Data from Multiple PCSs

Exaquantum is able to refine the data from disparate data sources into high-value business information, often known as Key Performance Indicators (KPIs). For example, tonnage of a product can be calculated from a flow measured by a PCS and a density measurement provided by a Laboratory Management Information System (LIMS).

### ● Time Resolved Alarm and Event History

Exaquantum can read, historize and display Alarms & Events received from compliant OPC A&E interfaces, which can be presented in time order for analysis.

For industries where unplanned shutdowns follow a complex series of consequential events, this facility can be very valuable in identifying the original cause of the shutdown.

### ● An Integrated Platform

The Exaquantum philosophy of open access to data and information enables easy configuration and integration of application software.

Typical data flows between applications are the passing of:

- Sample results transferred from LIMS to Exaquantum can be used for displays, reports and the calculation of KPIs.
- Inventory and QA data from Exaquantum to an ERP system to optimize planning and scheduling campaigns.
- Condition monitoring data from Exaquantum to maintenance software to automatically initiate repairs and optimize Planned Maintenance Management schedules.

### ● Long Term History

Long-term historization of plant data by Exaquantum creates the opportunity for further analysis to take place.

Example 1: A system can be set to automatic or manual mode. Analysis of plant history can prove the success of the control settings and monitor their ongoing usage.

Example 2: A LIMS value may indicate a trend leading towards an out-of-spec product. Operators and engineers have the opportunity to implement a correction before waste products are created.

Example 3: The flow meter on a main product stream may be inaccurate by several percent indicating leaks or measurement errors. The measurements from other flow meters on connected streams can be used to identify an alternative, accurate measurement for the main product stream.

● **Event Triggered Batch Processing**

Batch applications can be notified automatically if any steps or changes occur in the process. These changes may originate from direct process measurements however they can also be the result of Exaquantum aggregations or calculations. Exaquantum is the standard route for any application that requires event notification from any PCS, thus minimizing development costs.

● **IT Security**

Legacy and Standard security levels are available allowing compliance with system security requirements.

● **Microsoft SQL Server 2017 Standard (R3.30 or later)**

Exaquantum installation includes Microsoft SQL Server as an Integrated Value Added Solution.

● **Exaopc Product Security Support (R2.70 or later)**

Exaquantum has adopted the same security function as Exaopc R3.70 (\*1) which tightens the security for accessing process control systems (such as CENTUM).

\*1: Exaopc (R3.70 or later) can set limits on data access for each user account connecting to Exaopc.

■ **SYSTEM SPECIFICATION**

Item	Specification (*1)
Maximum number of tags	Maximum 500,000 tags (*2)
Throughput of Exaquantum (Maximum data acquisition)	600,000 tags/minute (*3)
Data item gathering interval (minimum)	1 second (*4)
Data item data historization interval (minimum)	1 second (*4)
Number of concurrent users (Exaquantum/Explorer)	Up to 64/server
Number of concurrent users (Exaquantum/Web)	Up to 100 for 1 Exaquantum Web Server
Number of connected physical OPC servers per Exaquantum server	Maximum of 35 OPC DA (*5) and HDA servers per Exaquantum Server (Maximum of 31 OPC A&E servers per Exaquantum Server (*6) (*7))

- \*1: A suitable hardware platform and infrastructure (network) must be chosen to support the required sizing.
- \*2: Deployed across single or Multi-servers up to a maximum of 500,000 tags.  
In case of Multi servers, for a maximum of five (5) Exaquantum servers.
- \*3: Select an appropriate number of RAID-1 or RAID-5 disks depending on the update rate as illustrated in the examples contained in the 'Hardware Disk Drive Configuration' section below.
- \*4: Depends on the OPC server performance.
- \*5: Number of connected OPC DA is included in OPC UA DA Server.
- \*6: The maximum number of supported A&E OPC servers is 31.  
The combined total from all connected physical OPC server(s) is not to exceed 130 messages per second.
- \*7: When using process data from tags from other Exaquantum servers in calculations, then the Exaquantum servers are included in the number of connected OPC gateways.

## ■ OPERATING ENVIRONMENT

### ● Hardware Operating Environment

The minimum requirements for the hardware and software operating environments are described in the tables below. Please contact the Yokogawa representative for large or non-standard systems requirements.

#### Exaquantum Server (real-time and historical database)

CPU: Intel x64 architecture as shown below

No. of tags	Required CPU Specifications
Less than 20,000 tags	Xeon dual core 2 GHz or higher
20,000 - 50,000 tags	Xeon dual core 3 GHz or higher
50,000 - 100,000 tags	Xeon 4 core 3 GHz or higher
100,000 - 500,000 tags	Xeon 8 core 3 GHz or higher with Hyper-Threading enabled

Note: Please consider the number of Alarm and Event when required CPU Specification is considered. For details, please contact your Yokogawa representative.

#### Main memory capacity

No. of tags	Operating System	Main Memory capacity
Less than 20,000 tags	Windows Server 2012 Standard 64-bit	8 GB or more
	Windows Server 2012 R2 Standard 64-bit	
	Windows Server 2016 Standard 64-bit	
	Windows Server 2019 Standard 64-bit	
20,000 tags - 100,000 tags	Windows Server 2012 Standard 64-bit	10 GB or more
	Windows Server 2012 R2 Standard 64-bit	
	Windows Server 2016 Standard 64-bit	
	Windows Server 2019 Standard 64-bit	
100,000 tags - 300,000 tags	Windows Server 2012 Standard 64-bit	32 GB or more
	Windows Server 2012 R2 Standard 64-bit	
	Windows Server 2016 Standard 64-bit	
	Windows Server 2019 Standard 64-bit	
300,000 tags - 500,000 tags	Windows Server 2012 Standard 64-bit	64 GB or more
	Windows Server 2012 R2 Standard 64-bit	
	Windows Server 2016 Standard 64-bit	
	Windows Server 2019 Standard 64-bit	

Note: Please combine the required capacity when another software is to be installed on the Exaquantum.

Disk capacity: Depends on the process data scan rate and retention period.

The disk free space required for installation is:

- System drive: minimum 8 GB (\*1)
- SQL server installed drive: minimum 8 GB (\*2)

\*1: 16 GB or more empty space in main memory is required when a SQL server is installed on a system drive.

\*2: 1 TB or more empty space in disk is required when OPC CAMS for HIS or UACS A&E messages are collected and saved.

#### Hardware disk drive details

Throughput	Details
Less than 2,000 data/second (*1)	Refer to "Example 1: Less than 2,000 updates/second"
2,000 - 5,000 data/second	Refer to "Example 2: 2,000 updates/second to 5,000 updates/second"
5,000 - 10,000 data/second	Refer to "Example 3: 5,000 updates/second to 10,000 updates/second"

\*1: Yokogawa's Global PC can be used.



**Hardware Disk Drive Configuration**

In order to improve disk fault tolerance, configure all disks as RAID-1 or RAID-5 with cache provided.

Due to the high performance disk requirements of Exaquantum, SAS interfaces are recommended for all Exaquantum disks.

The following provides example disk specifications to meet the required OPC DA update rate.

**Example 1: Less than 2,000 updates/second**

Configure one RAID array for installation of all items.

Array No.	Minimum Write Speed	Hardware Speed	Hardware Interface	RAID Array Recommendation	Installation item
1	100 Mbyte/sec	10,000 rpm	6 G b/s SAS	RAID-5 (3 or more disks)	Operating System
					Applications (including Exaquantum Software)
					SQL Program files
					SQL Data files
					SQL Log files
Online/Offline Archives					

**Example 2: 2,000 updates/second to 5,000 updates/second**

Configure three RAID arrays for installation of all items.

Array No.	Minimum Write Speed	Hardware Speed	Hardware Interface	RAID Array Recommendation	Installation item
1	100 Mbyte/sec	15,000 rpm	6 G b/s SAS	RAID-5 (3 or more disks)	Operating System
					Applications (including Exaquantum Software)
					SQL Program files
2	200 Mbyte/sec	15,000 rpm	6 G b/s SAS	RAID-5 (4 or more disks)	SQL Data files
					SQL Log files
3	200 Mbyte/sec	15,000 rpm	6 G b/s SAS	RAID-5 (4 or more disks)	Online/Offline Archives

**Example 3: 5,000 updates/second to 10,000 updates/second**

Configure four RAID arrays for installation of all items.

Array No.	Minimum Write Speed	Hardware Speed	Hardware Interface	RAID Array Recommendation	Installation item
1	100 Mbyte/sec	15,000 rpm	6 G b/s SAS	RAID-5 (3 or more disks)	Operating System
					Applications (including Exaquantum Software)
					SQL Program files
2	300 Mbyte/sec	15,000 rpm	6 G b/s SAS	RAID-5 (6 or more disks)	SQL Data files
3	300 Mbyte/sec	15,000 rpm	6 G b/s SAS	RAID-5 (6 or more disks)	SQL Log files
4	300 Mbyte/sec	15,000 rpm	6 G b/s SAS	RAID-5 (6 or more disks)	Online/Offline Archives

**Web Server**

CPU: Intel x64 architecture Xeon dual core 2 GHz or higher

Main memory capacity

Operating System	Main Memory capacity
Windows Server 2012 Standard 64-bit	8 GB or more
Windows Server 2012 R2 Standard 64-bit	
Windows Server 2016 Standard 64-bit	
Windows Server 2019 Standard 64-bit	

Disk capacity: 2 GB or more

Note: The above hardware environment is suitable when the Exaquantum server and Web server are installed on different servers. Please combine the required capacity if the Web server is to be installed on the Exaquantum server.

**Exaquantum User PCs**

<b>CPU</b>	Equivalent to Intel Core i3 dual core 1.33 GHz or higher
<b>Main RAM Memory Capacity</b>	4 GB or more
<b>Disk capacity</b>	2 GB or more, 3 GB or more (in case of using MS Excel)
<b>Resolution</b>	1024 × 768 or better
<b>Display colors</b>	65,536 or more

Note: When an Exaquantum client is installed on a HIS, please follow the operational environment specified by the standard operation and monitoring function (LHS1100, LHM1101, VP6H1100).

Note: Please combine the required capacity when another software is to be installed on Exaquantum.

**Tablet PCs**

	<b>Apple - iPad</b>	<b>Windows - Tablets</b>
<b>Retina resolution</b>	2048 × 1536	2160 × 1440
<b>Non-Retina resolution</b>	1024 × 768	1920 × 1080, 1366 × 768 or 1024 × 768
<b>Size</b>	7 inches or more	7 inches or more

Note: As for the Tablet PC, touch panel behavior only is confirmed.

**PI OPC Interface PC**

<b>CPU</b>	Equivalent to Core i3 dual core 2.50 GHz or higher
<b>Main memory</b>	2 GB or more
<b>Disk capacity</b>	Requires following free space for installation.
<b>System drive</b>	Minimum 2 GB required (40 GB recommended)

**● Software Operating Environment**

The packages contained in the Software Specification may support either '64-bit' or '32-bit' versions. If either '64-bit' or '32-bit' is not listed then only the 32-bit version is supported.

<b>Hardware</b>	<b>Software Specification</b>
Exaquantum Server	<Operating System> <ul style="list-style-type: none"> <li>• Windows Server 2019 Standard 64-bit (*1)</li> <li>• Windows Server 2016 Standard 64-bit (*1)</li> <li>• Windows Server 2012 R2 Standard 64-bit (*1)</li> <li>• Windows Server 2012 Standard 64-bit (*1)</li> </ul> <Other Software> <ul style="list-style-type: none"> <li>• Microsoft SQL Server 2017 Standard 64-bit (*2)</li> <li>• Microsoft Excel or Office 2013 (32-bit) / 2016 (32-bit) / 2019 (32-bit / 64-bit) / Microsoft 365 (32-bit / 64-bit) (*3) (*4)</li> <li>• Microsoft Internet Explorer 11.0</li> <li>• Adobe Reader 10.1/11.0/DC (*5)</li> </ul>
Exaquantum Web Server	< Operating System > <ul style="list-style-type: none"> <li>• Windows Server 2019 Standard 64-bit (*1)</li> <li>• Windows Server 2016 Standard 64-bit (*1)</li> <li>• Windows Server 2012 R2 Standard 64-bit (*1)</li> <li>• Windows Server 2012 Standard 64-bit (*1)</li> </ul> < Other Software > <ul style="list-style-type: none"> <li>• Microsoft Internet Explorer 11.0</li> <li>• Internet Information Services (IIS)</li> <li>• Adobe Reader 10.1/11.0/DC (*5)</li> </ul>

\*1: Exaquantum is a 32-bit application that can be installed with the WOW64 emulation environment provided with the 64-bit OS.

\*2: SQL Server (Main server modules are 64-bit) runtime version is bundled with Exaquantum. Microsoft SQL Server can only be used by Exaquantum as stated in the SQL Server license certificate.

\*3: Supported Editions of Excel 2013 are listed below (Volume License Editions):

- Excel 2013
- Office Standard 2013
- Office Professional Plus 2013

Supported Editions of Excel 2016 are listed below (Volume License Editions):

- Excel 2016
- Office Standard 2016
- Office Professional Plus 2016



Supported Editions of Excel 2019 are listed below(Volume License Editions) :

- Excel 2019
- Office Standard 2019
- Office Professional Plus 2019

Supported Editions of Excel 365 are listed below (Click To Run Editions) (C2R):

- Excel 365
- Microsoft Standard 365

As for Microsoft 365 version, refer to the following Yokogawa Web site for the support status.

[https://www.yokogawa.com/solutions/products-platforms/solution-based-software/data-historian/data-historian-exaquantum/#Details\\_Support-info](https://www.yokogawa.com/solutions/products-platforms/solution-based-software/data-historian/data-historian-exaquantum/#Details_Support-info)

- \*4: There are sometimes compatibility issues, when opening Excel documents created on different OS or version of Excel. There is a workaround for these problems, described in Exaquantum/Explorer User's Manual Volume 3 - Excel Reports (IM36J04A12-03E).
- \*5: Adobe Reader is required to browse Exaquantum R2.50 or later manuals.

Hardware	Software Specification
User PCs for Exaquantum/ Explorer, Exaquantum/Web Client (*8)	<Operating System> <ul style="list-style-type: none"> <li>• Windows Server 2019 Standard 64-bit (*1)</li> <li>• Windows Server 2016 Standard 64-bit (*1)</li> <li>• Windows Server 2012 R2 Standard 64-bit (*1)</li> <li>• Windows Server 2012 Standard 64-bit (*1)</li> <li>• Windows 10 Enterprise 2015 LTSC 64-bit (*1)</li> <li>• Windows 10 Enterprise 2016 LTSC 64-bit (*1)</li> <li>• Windows 10 Enterprise 2019 LTSC 64-bit (*1)</li> <li>• Windows 10 IoT Enterprise 2016 LTSC 64-bit (*1)</li> <li>• Windows 10 IoT Enterprise 2019 LTSC 64-bit (*1)</li> <li>• Windows 10 Pro SAC 64-bit (*7)</li> <li>• Windows 10 Enterprise SAC 64-bit (*7)</li> <li>• Microsoft Excel or Office 2013 (32-bit) / 2016 (32-bit) / 2019 (32-bit/64-bit) / Microsoft 365 (32-bit/64-bit) (*2)</li> <li>• Microsoft Internet Explorer 11.0</li> <li>• Adobe Reader 10.1/11.0/DC (*3)</li> </ul>
PI OPC Interface PC (*4)	<Operating System> (*4)
Tablet device on Web Client (Supported on R3.01 or later)	<Operating System> <ul style="list-style-type: none"> <li>• iOS (From iOS 9 or more can be guaranteed) (*5) (*6)</li> <li>• Windows 10 Tablet (*5) (*6)</li> </ul>

LTSC: Long Term Servicing Channel

SAC: Semi-Annual Channel

- \*1: Exaquantum is a 32-bit application that can be installed with the WOW64 emulation environment provided with the 64-bit OS.
- \*2: Supported Editions of Excel 2013 are listed below (Volume License Editions):
  - Excel 2013
  - Office Standard 2013
  - Office Professional Plus 2013
 Supported Editions of Excel 2016 are listed below (Volume License Editions):
  - Excel 2016
  - Office Standard 2016
  - Office Professional Plus 2016
 Supported Editions of Excel 2019 are listed below(Volume License Editions) :
  - Excel 2019
  - Office Standard 2019
  - Office Professional Plus 2019
 Supported Editions of Excel 365 are listed below (Click To Run Editions): (C2R)
  - Excel 365
  - Microsoft Standard 365
 As for Microsoft 365 version, refer to the following Yokogawa Web site for the support status.
 

[https://www.yokogawa.com/solutions/products-platforms/solution-based-software/data-historian/data-historian-exaquantum/#Details\\_Support-info](https://www.yokogawa.com/solutions/products-platforms/solution-based-software/data-historian/data-historian-exaquantum/#Details_Support-info)
- \*3: Adobe Reader is required to browse Exaquantum R2.50 or later manuals.
- \*4: When PI is used, please contact your Yokogawa representative.
- \*5: Legacy Exaquantum/Web is not supported.
- \*6: Exaquantum/Explorer and Excel Add-In are not supported.
- \*7: The support policy in regard to operating system will depend on the policy of Microsoft. If any problems occur in the OS during the additional servicing period of OS or after the end of support date, the service support might be charged by Microsoft and this will be out of scope for maintenance service for Exaquantum (SV3NTMP001). Some functions of the Exaquantum/Explore and Exaquantum/Web client may possibly be restricted when Windows Update is applied to Windows 10 SAC. Refer to the following Yokogawa Web site for the support status.
 

[https://www.yokogawa.com/solutions/products-platforms/solution-based-software/data-historian/data-historian-exaquantum/#Details\\_Support-info](https://www.yokogawa.com/solutions/products-platforms/solution-based-software/data-historian/data-historian-exaquantum/#Details_Support-info)
- \*8: Exaquantum/Web Client does not support Microsoft Edge.

● **Virtualization platform (R3.15 or later)**

Exaquantum can run on virtualization platform.  
Please refer to the GS “IA System Products Virtualization Platform” (GS 30A05B10-01EN) about details.

● **Co-existence or combination of Exaquantum and other solution-based software packages (SBP) (\*1)**

The definition of terms ‘co-existence’ and ‘combination’ is as follows:

- Co-existence: Exaquantum and other SBP products reside on the same PC.
- Combination: Exaquantum communicates with Exaopc or HIS OPC over a LAN network.

\*1: Other SBP products include Exaopc, Exapilot, Exaquantum/Batch, and Exaplog.

● **Combination of Exaquantum and Exaopc OPC interface package via network**

- Exaquantum can be connected with Exaopc OPC interface package R3.10 or later.
- Exaquantum can be connected with Exaopc OPC interface package (for HIS) R3.05 or later.

Note: For detailed information, refer to GS;  
 • GS 33K05F10-50E LHS2411 Exaopc OPC Interface Package (for HIS)  
 • GS 33J05F10-01EN VP6H2411 Exaopc OPC Interface Package (for HIS)  
 • GS 36J02A10-01E NTPF100 Exaopc OPC Interface Package  
 However, either LHS2411 or VP6H2411 is used, History Catchup cannot be available.

Note: For detailed information, refer to GS 36J02A10-01E NTPF100 Exaopc OPC interface package. When Exaquantum is connected to Exaopc-RD, please contact your Yokogawa representative.

Note: The following Revision Numbers are required for Exaquantum to collect Alarms & Events from CAMS.  
 • Exaopc R3.72 or later  
 • CENTUM VP R5.03.20 or later

Note: The following Revision Numbers are required for Exaquantum to collect Alarms & Events from UACS  
 • Exaopc R3.78.10 or later  
 • CENTUM VP R6.07.10 or later

● **Precaution of connecting with SMARTDAC+**

When connecting to SMARTDAC+, ensure to meet the following requirement of SMARTDAC+;

- Firmware version R4.01.03 or later.
- When connecting to SMARTDAC+ by Exaquantum, ordering the SMARTDAC+ which come with E3 option is required. For more details, please refer to the GS of SMARTDAC+.

● **Restrictions in Co-existence of Exaquantum and other SBP products**

Exaquantum	SBP products	
	Server	Client
Server (PIMS or Web servers)	Table 1	Table1
Client	Table 1	Table 2

Note: IT Security model must be set to the ‘Legacy model’ if Exaquantum and other SBP products are installed on a single PC.

Co-existence tables for Exaquantum with other SBP products are as shown below:

Table 1:

	Exaopc (R3.79) (*2)	Exapilot (R3.98)	Exaquantum /Batch	Exaplog (R3.40) (*3)	Platform for Advanced Control and Estimation (R5.02.20)
Exaquantum (R3.30)	OK (*1)	OK	N/A	OK	N/A

Table 2:

	Exaopc (R3.79)	Exapilot (R3.98)	Exaquantum /Batch	Exaplog (R3.40) (*3)	Platform for Advanced Control and Estimation (R5.02.20)
Exaquantum (R3.30)	OK	OK	N/A	OK	OK

OK: Applicable                      N/A: Not Applicable

Note: Ensure other software operation environments such as OS are valid in addition to the variety of packages and their revisions.

\*1: In the case where the PIMS server and Web server are combined, Exaopc can be also installed.

\*2: Exaopc includes Exaopc-RD. Please contact Yokogawa when Exaopc resides with other revisions.

\*3: As for another revision, please contact your Yokogawa representative.

● **Restrictions in co-existence with HIS**

		CENTUM VP HIS (R6.07.10)
Exaquantum (R3.30)	Server	N/A
	Client	OK (*1)

OK: Applicable                      N/A: Not Applicable

Note: R3.20 IT security model for Exaquantum and other SBP products must be set to the same model when these packages are installed the same server.

Note: To ensure the variety of packages, their revisions and other operating environments such as the OS must be identical.

Note: When installing an Exaquantum client on CENTUM CS 3000 HIS, please contact your Yokogawa representative.

\*1: On CENTUM VP R4.03 or later, Legacy model or Standard model (Standalone and Domain) can coexist.

■ **MODELS AND SUFFIX CODES**

● **Exaquantum/PIMS**

An Exaquantum license authorizes tags (data points) up to the number specified by each suffix code. Exaquantum supports a maximum number of 500,000 tags, deployed across single or multiple servers. Only one DVD set is provided regardless of the number of servers, unless otherwise requested. Every client PC connected to Exaquantum/PIMS must be licensed. One or more Exaquantum/Explorer Per-Seat Client licenses are provided with each tag license.

		Description
<b>Model</b>	NTPP001	Exaquantum Data Server Package
<b>Suffix Codes</b>	-S	Basic Software License
	1	New Order (with Media)
	1	English version
	-00A5	500 Tags / 1 client
	-0001	1,000 Tags / 2 clients
	-0002	2,000 Tags / 4 clients
	-0003	3,000 Tags / 4 clients
	-0005	5,000 Tags / 4 clients
	-0007	7,500 Tags / 4 clients
	-0010	10,000 Tags / 10 clients
	-0020	20,000 Tags / 10 clients
	-0040	40,000 Tags / 10 clients
	-0060	60,000 Tags / 10 clients
	-0080	80,000 Tags / 10 clients
	-0099	100,000 Tags / 10 clients
	-00B2	200,000 Tags / 10 clients
	-00B3	300,000 Tags / 10 clients (R3.01 or later)
	-00B4	400,000 Tags / 10 clients (R3.01 or later)
-00B5	500,000 Tags / 10 clients (R3.01 or later)	

● **Exaquantum/Explorer (Per-Seat Licensing)**

This is an optional package for adding additional per-seat users to the NTPP001 package. Each license will allow an Exaquantum/Explorer client to be installed on a single client PC. All Exaquantum/Explorer client PCs must be licensed even if Microsoft Terminal Server is used.

		Description
<b>Model</b>	NTPP002	Exaquantum Client Per-Seat Licensing Interface Package
<b>Suffix Codes</b>	- S	Basic Software License
	1	Always 1
	1	English version
	-□□	Enter additional client licenses in □□ (01-99)

● **Exaquantum/Web Server**

This is an optional package for the NTPP001 package. The number of Web servers required should be based upon the number of concurrent users because more than one Web server may be required to prevent overloading. In the case of more than 100 Web clients, please use more than one Web Server with a sufficient server specification. Please contact your Yokogawa representative for assistance.

		Description
<b>Model</b>	NTPP003	Exaquantum Web Server Package
<b>Suffix Codes</b>	- S	Basic Software License
	1	Always 1
	1	English version
	-□□	Enter number of Web servers required in □□ (01-99)

● **Exaquantum/Web Client (Per-Seat Licensing)**

This is an optional package for adding web users, requiring both NTPP001 and NTPP003. Each Exaquantum/Web client PC or Tablet PC connected to Exaquantum must be licensed. Each license allows an Exaquantum/Web client to be installed on a single client PC. However, web users are not bound to any one PC and therefore user profiles are used to control access to Exaquantum.

		Description
<b>Model</b>	NTPP004	Exaquantum Web Client Package
<b>Suffix Codes</b>	- S	Basic Software License
	1	Always 1
	1	English version
	-□□	Enter number of per-seat Web client licenses required in □□ (01-99)

● **Exaquantum GUI Conversion Tool**

This is an optional package that requires the NTPP001 package. It provides conversion of graphics files suitable for display within Exaquantum/Explorer and Exaquantum/Web screens.

		Description
<b>Model</b>	NTPP005	Exaquantum GUI Conversion Tool
<b>Suffix Codes</b>	- S	Basic Software License
	1	Always 1
	1	English version
	E	CENTUM VP/CENTUM CS 3000 Graphics to Exaquantum/Explorer format
	W	CENTUM VP/CENTUM CS 3000 Graphics to Exaquantum/Web format

● **Exaquantum/Explorer (2:1 Concurrent Licensing)**

This is an optional package for adding new or additional concurrent users to the NTPP001 package.

Each concurrent license will allow an Exaquantum/Explorer client to be installed on two PCs however only one Exaquantum/Explorer client can be used at one time. For example, if NTPP006-S11-02 is purchased then Exaquantum/Explorer can be installed on four PCs where any two of the four PCs can be connected to Exaquantum at the same time.

All Exaquantum/Explorer client PCs must be licensed even if Microsoft Terminal Server is used.

		Description
<b>Model</b>	NTPP006	Exaquantum User 2:1 Concurrent Licensing Interface Package
<b>Suffix Codes</b>	- S	Basic Software License
	1	Always 1
	1	English version
	-□□	Enter new or additional concurrent client licenses in □□ (01-99)

● **Exaquantum Open Interface**

This is an optional package for the NTPP001 package to allow access to Exaquantum process data via OPC DA 2.05a and HDA 1.1. This package is also required for each Exaquantum server providing tag data to Exaquantum calculated tags located in another Exaquantum server.

		Description
<b>Model</b>	NTPP007	Exaquantum Open Interface function
<b>Suffix Codes</b>	- S	Basic Software License
	1	Always 1
	1	English version
	-□□	Enter number of Exaquantum Open Interface function licenses in □□ (01-05)

● **Additional Exaquantum Server License**

This is an optional package to license Exaquantum servers within an Exaquantum multi-server environment.

		Description
<b>Model</b>	NTPP008	Additional Exaquantum Servers
<b>Suffix Codes</b>	- S	Basic Software License
	1	Always 1
	1	English version
	-□□	Enter number of new or additional Exaquantum server Licenses in □□ (01-04)

● **Exaquantum Additional Tags**

This is an optional for adding additional Exaquantum tags to the NTPP001 package.

		Description
<b>Model</b>	NTPP009	Exaquantum/PIMS Tags for Upgrade
<b>Suffix Codes</b>	- S	Basic Software License
	2	For Upgrade of 500,000 or less Exaquantum tags
	1	English version
<b>Option Codes (*1)</b>	/S□□□	Enter number of additional Exaquantum tags in groups of 1,000 until a maximum total of 10,000 tags are reached.
	/M□□□	Enter number of additional Exaquantum tags in groups of 1,000 until a maximum total of 20,000 tags are reached. This can only be ordered when the previous tier has been reached.
	/L□□□	Enter number of additional Exaquantum tags in groups of 1,000 until a maximum total of 100,000 tags are reached. This can only be ordered when the previous tier has been reached.
	/X□□□	Enter number of additional Exaquantum tags in groups of 1,000 until a maximum total 500,000 tags are reached. This can only be ordered when the previous tier has been reached. (R3.01 or later)

\*1: Addition of the number of tags to NTPP001

■ **ANNUAL MAINTENANCE CONTRACT**

The product is supplied without the manufacturer’s warranty costs. A warranty is obtained by purchasing an Annual Maintenance Contract (AMC), which covers a specified (contract) time period (usually 1 year). It is mandatory that an AMC(s) is purchased when a Solution Based Software license products is ordered. The AMC will start on the date that the license product is delivered to the Yokogawa Sales Office. You cannot order an optional software product, unless an active AMC for the existing Solution Based Software license has been purchased.

For more details of the maintenance service, please refer to the “Maintenance Services for Solution-Based Software Package” (GS 36J20A10-01E).



● **Exaquantum Maintenance Service**

		Description
<b>Model</b>	SV3NTMP001	Exaquantum Maintenance Service
<b>Suffix Codes</b>	- S	Annual Contract
	1	Always 1
	1	Always 1
	-A5	500 Tags / 1 client
	-01	1,000 Tags / 2 clients
	-02	2,000 Tags / 4 clients
	-03	3,000 Tags / 4 clients
	-05	5,000 Tags / 4 clients
	-07	7,500 Tags / 4 clients
	-10	10,000 Tags / 10 clients
	-20	20,000 Tags / 10 clients
	-40	40,000 Tags / 10 clients
	-60	60,000 Tags / 10 clients
	-80	80,000 Tags / 10 clients
	-99	100,000 Tags / 10 clients
	-B2	200,000 Tags / 10 clients
	-B3	300,000 Tags / 10 clients (R3.01 or later)
	-B4	400,000 Tags / 10 clients (R3.01 or later)
	-B5	500,000 Tags / 10 clients (R3.01 or later)
	-YY	When ordering using the Option Code (below)
-N	New	
-R	Renewal	
<b>Option Codes</b>	/S□□□	Enter number of additional Exaquantum tags in groups of 1,000 until a maximum total of 10,000 tags are reached.
	/M□□□	Enter number of additional Exaquantum tags in groups of 1,000 until a maximum total of 20,000 tags are reached. This can only be ordered when the previous tier has been reached.
	/L□□□	Enter number of additional Exaquantum tags in groups of 1,000 until a maximum total of 100,000 tags are reached. This can only be ordered when the previous tier has been reached.
	/X□□□	Enter number of additional Exaquantum tags in groups of 1,000 until a maximum total of 500,000 tags are reached. This can only be ordered when the previous tier has been reached.
	/UI□□	Enter number of Exaquantum/Explorer Licenses in □□ (01 - 99).
	/UC□□	Enter number of Exaquantum/Explorer 2:1 Concurrent Licenses in □□ (01 - 99).
	/WS□□	Enter number of Exaquantum Web server in □□ (01 - 99).
	/WC□□	Enter the number of Exaquantum/Web server named user Licenses in □□ (01 - 99).
	/GE	Exaquantum GUI Conversion Tool (Exaquantum/Explorer format).
	/GW	Exaquantum GUI Conversion Tool (Exaquantum/Web format).
	/OP□□	Enter number of Exaquantum Open Interface in □□ (01- 05).
	/ML□□	Enter number of Exaquantum multi-server Licenses in □□ (01 - 04).

■ **TRADEMARK ACKNOWLEDGMENT**

The names of corporations, organizations, products and logos herein are either registered trademarks or trademarks of Yokogawa Electric Corporation and their respective holders.