

General Specifications

NTPS200
Exapilot
Operation Efficiency Improvement Package



GS 36J06B10-01E

OVERVIEW

One of the major concerns in the plant operations is how to reduce its operation costs so that the profit is optimized. The industrial plant operations are fully automated with process control systems (PCS); however, startup, shutdown, load/grade changes, and other non-routine works are largely done by manual operations. The operation efficiencies can further be improved by automating these non-routine operations as much as possible.

Exapilot operation efficiency improvement package is a tool to help operators create semi-automatic sequences to replace non-routine and manual operations in the plant. Designed easy to use, Exapilot realizes continuous improvements in operating efficiencies. Improvements are applicable to the following areas.

- Reduce operation hours while maintaining product quality
- Save labor cost without disturbing safe plant operations
- Prevent operation errors
- Standardize operating procedures and operation methods regardless of the operator skill levels
- Ensure experienced operators' know-how is maintained
- Provide opportunities for operators to gain further knowledge about the plant and processes.

Exapilot runs on a general PC or it coexists on a human interface station (HIS) of the CENTUM production control system. It also connects with other control instruments via open product connectivity (OPC) standard interface.

PACKAGE OVERVIEW

Automating manual or non-routine procedures with PCS requires a lot of configuration and engineering work. Even the process is automated, it requires modifications in applications whenever the equipments or production recipes are changed, which adds up to the maintenance cost.

Exapilot is equipped with tools and functions to solve these problems. It is easy to design, configure, modify, and maintain the operating procedures to automate non-routine works.

Exapilot's builder functions provides typical procedural components such as pump start/stop, valve positioning, ramp up/down, request field work, pause, wait for a condition, and so on. By linking these components on the screen, an experienced operator is able to create a procedural flow chart that automates the non-routine sequence into semi-automatic one. The created sequence can also be used as a navigation guide on a screen for operations.

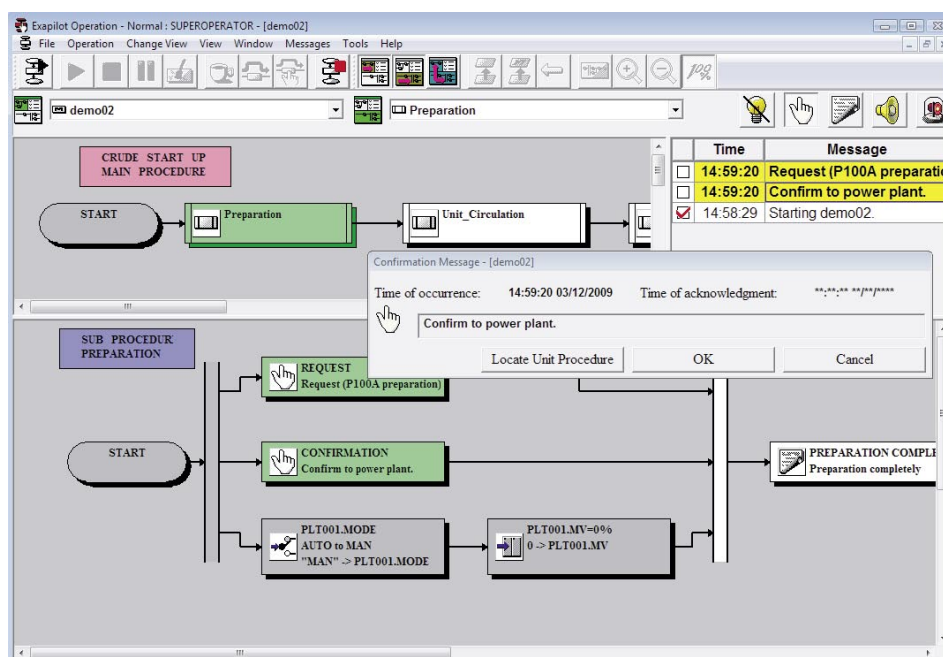
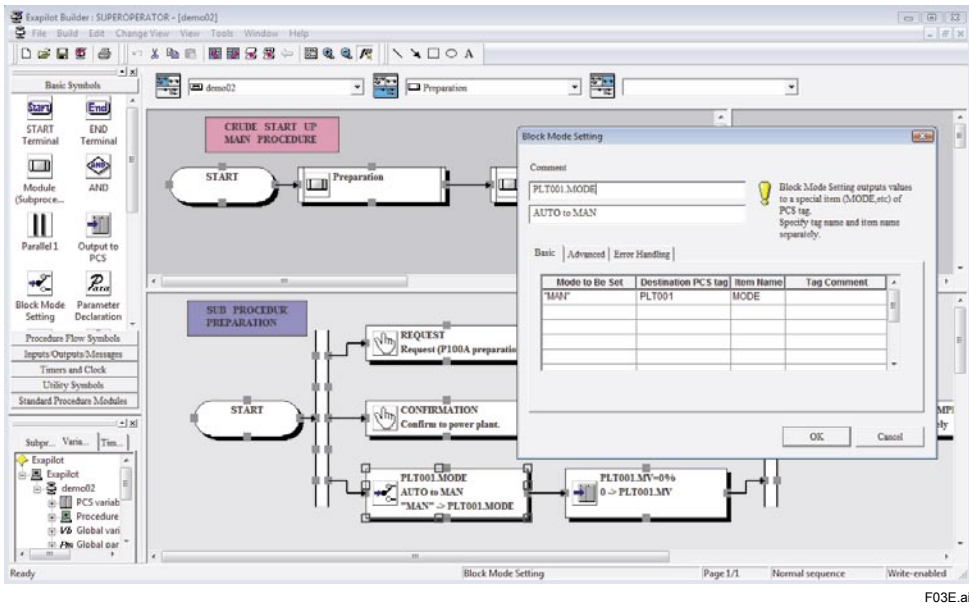

Figure: Exapilot Operation Main Window

F01E.ai



F03E.ai

Figure: Exapilot Builder Main Window

■ FUNCTION OVERVIEW contd.

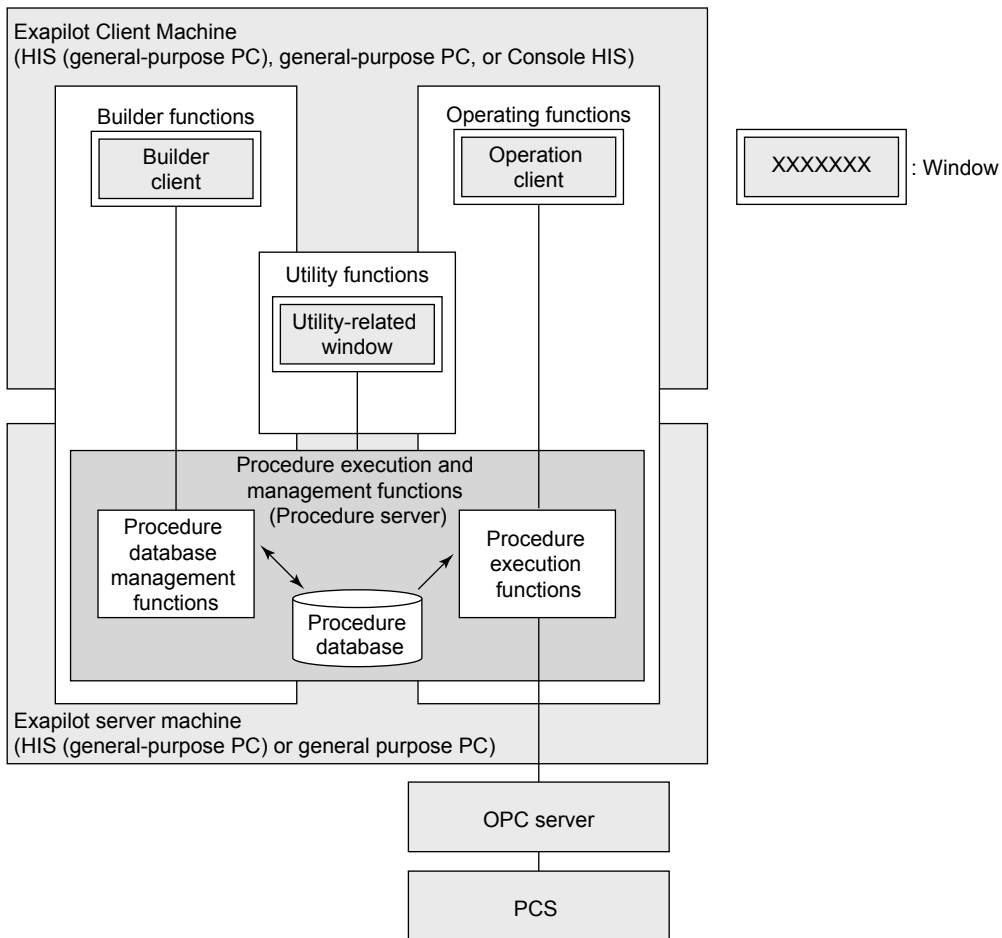

F05E.ai

Figure: Exapilot Function Overview

● **Builder Functions**

Provides an environment easy to create and configure operation procedures.

Procedure builder functions

- Procedure flow builder function
- Procedure flow documentation function
 - Header/footer setting
 - Print out setting
- Character variable functions
- PCS tag existence-checking functions
- Parameter (variable) declaration check functions

Operating procedure parts functions

- Procedural modules
- User-made (with Visual C language) procedural module

● **Operating Functions**

A procedural flow window to display and a monitor operation status are provided. Operational instructions can be given in details.

Operation monitoring functions

- Operation procedure display
- Operation data display
- Output history display

Operating functions

- Operation start/stop commands
- Detailed operation commands (skip, break, and pause)
- Operation message display

● **Procedure Execution and Management Functions**

The operation procedures created by the builder functions can be managed and executed.

Procedure execution functions

- Controls procedural flow
- Client/server function
- Multiple procedures execution function
- Offline function
- Test run function
- PCS output confirmation function

Procedure database management functions

- Procedure flow display functions (display data processing, database editing, and syntax check)

● **Utility Functions**

Provides necessary functions for managing Exapilot software package.

Utility Functions

- Installer function
- System parameter setting function
- Procedure maintenance function
- Multiple OPC servers connecting function
- Security function
- Historical report (message) function
- Historical report (PCS output history) function
- Watchdog notification and operation status monitoring function
- Event record management function

● **Tool**

- Save/restore procedures tool
- Prepare to run Main Procedures tool
- Variable display tool

■ PROCEDURE CONFIGURATION

On Exapilot the series of operation and monitoring sequence are described on flow chart style or logic chart style, called "Procedure".

Procedure Configuration

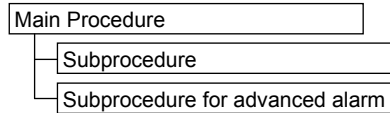

Procedure Elements

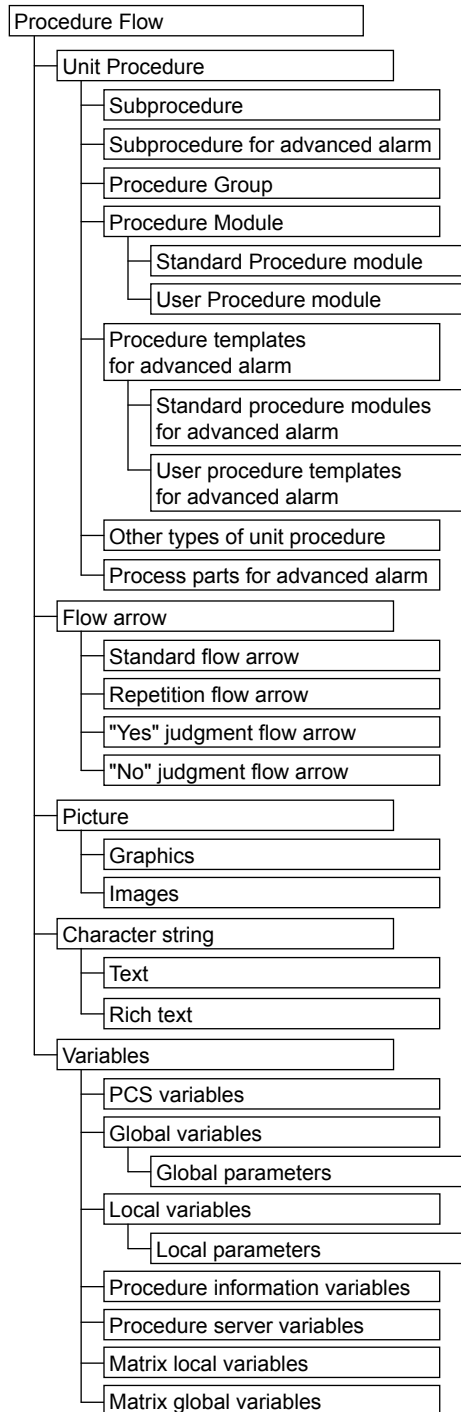

F01-1E.ai

Procedure Configuration

Main Procedure: Individual operating procedure units, each with individual names (Example: Boiler start-up).

Subprocedure: Units which are part of the hierarchy below the main procedure and have individual names (Example: Heating process).

Subprocedure for advanced alarm: Advanced alarm units which are part of the hierarchy below the main procedure and have individual names (Example: Valve failure monitoring).

Procedure Elements

Procedure Flow: Individually-defined operating procedures

Unit Procedure: A process associated with a single procedure flow.

Subprocedure: Special unit procedure representing a process hierarchy

Subprocedure for advanced alarm: Special unit procedure used to represent the hierarchy of the procedure for advanced alarm.

Procedure Group: Special subprocedure representing a group of unit procedures.

Procedure Module: Special unit procedure used to represent a subprocedure part registered in a library.

Standard Procedure Module: Module provided as standard by Yokogawa.

User Procedure Module: Module created by user (and registered in a library).

Procedure templates for advanced alarm: Special unit procedure equivalent to a subprocedure for advanced alarm designed as a component (and registered in a library).

Standard procedure modules for advanced alarm: Procedure templates for advanced alarm provided as standard by Yokogawa

User procedure templates for advanced alarm: Component subprocedure for advanced alarm created by user (and registered in a library).

Other types of unit procedure: The minimum elements configuring the Procedure flow

Process parts for advanced alarm: The unit procedures which can be used in a procedure for advanced alarm.

-
- Flow arrow: Structural element used to represent a procedure and connect subprocedures in a flow chart.
 - Standard flow arrow: Starts from one subprocedure (other than a decision subprocedure) and connects to another, defining the order in which they are processed.
 - Repetition flow arrow: Loops back to previous processing (used to perform repeated processing).
 - “Yes” judgment flow arrow: Branches to process corresponding to “Yes” decision.
 - “No” judgment flow arrow: Branches to process corresponding to “No” decision.
 - Picture: Graphics (JPEG or bitmap) to be pasted on the work space and figure (circle or line).
 - Character string: Program element for which a string of characters, a rich text or a hyperlink can be specified.
 - Variables: Data used in Exapilot.
 - PCS variables: Variables used to transmit data between Exapilot and PCS.
 - Global variables: Variables declared as global (main-procedure-level) variables
 - Global parameters: Variables declared as global (main-procedure-level) parameters; can be modified by user.
 - Local variables: Variables declared as local (subprocedure-level) variables
 - Local parameters: Variables declared as local (subprocedure-level) parameters; can be modified by user.
 - Procedure information variables: Variables in which main procedure specific information is stored.
 - Procedure server variables: Variables the procedure server manages.
 - Matrix local variables: Local variables with one-dimensional array or two-dimensional array
 - Matrix global variables: Global variables with one-dimensional array or two-dimensional array

■ PROCEDURE FLOW

Exapilot creates an operation procedure described in the form of a flow chart, which is called a procedure flow. By placing subprocedures or unit modules in between the start/end terminals, it describes operation sequences in order. The main procedure describes the top-level major operations while the subprocedures describe unit procedures or sub-procedures in more details. An application contains up to 300 levels of subprocedures.

● Structure Sample

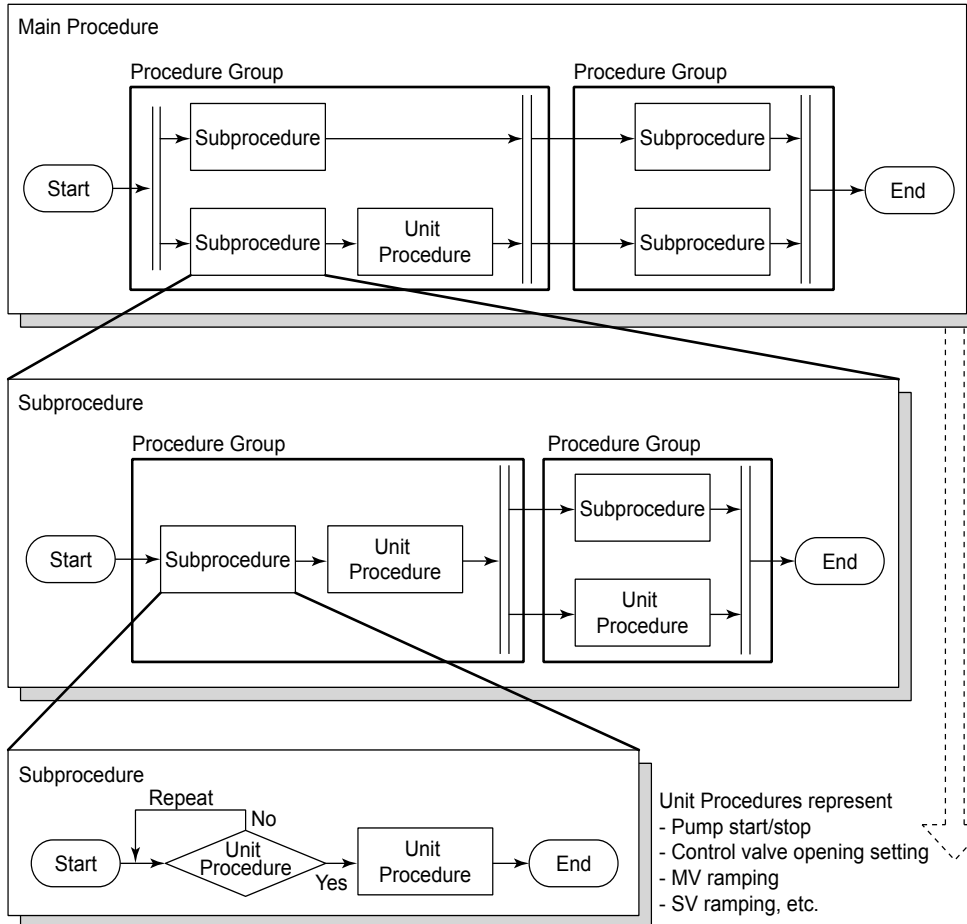

F02E.ai

● Unit Procedures

Unit Procedures	Function / Unit Procedure Name
Procedure flow symbols	A unit procedure used to represent a procedure in a flowchart format START terminal, END terminal, Subprocedure, Parallel 1, Parallel 2, AND, OR, Branch 1, Branch 2, Output connector, Input connector
I/O Messages	Input processing, Output processing, Unit procedures with message processing functions Output to PCS, Block mode Setting, Input from other main procedures' variables, Output to other main procedures' variables, Confirmation Messages, Guidance Messages, Alarm Messages, Calculations, Substitution, HIS Operator Guide Messages, HIS Alarm Messages, HIS Window, Event Wait, User Event Wait, String Operation, Statistic Processing, User Event Transmission, Start of User Event Driven, End of User Event Driven, Reset of User Event, Matrix Calculation
Timer block	Time processing, Unit procedures with time-series processing functions Timer, Clock, Start Timer, Stop Timer, Check elapsed time, Pause Timer, Restart Timer
Utilities	In addition, unit procedures required to create various procedure flows Parameter declaration, Pause, Start subprocedure command, Initialize subprocedure command, Judge subprocedure status, End subprocedure command, Pause subprocedure command, End main procedure command, Pause main procedure command, Start other main procedure command, Judge other main procedure status, End other main procedure command, User function, Procedure group label, Comment, Generic name declaration, Dynamical generic name, Event Record Search, Search, Matrix Search, User Application, End, Matrix Declaration

■ FEATURES AND FUNCTIONS

● System structure

Client/server function

Exapilot client PCs can access to an Exapilot server PC for remote engineering and remote operations.

Seamless connection with PCS (*1)

Exapilot adopts open product connectivity (OPC) standard interface for connecting with PCS, such as Yokogawa's CENTUM series systems as well as the third party systems including PLC systems. When connecting with the third party PCS, check interoperability of the OPC server individually.

Note: Please contact Yokogawa when connecting Exapilot with the third party OPC server.

*1: Exapilot Office is not supported. Exapilot for HIS accepts only inputs from PCS.

Supporting redundant Exaopc

Exaopc OPC server redundancy function (Model: NTPF100 Exaopc-RD) is supported. The package can be applied for configuring a redundant system.

● Builder

Intuitive GUI

Exapilot describes an operation procedure in flowchart format. It requires no special programming language, but simply follows the instructions to build, debug, operate, and maintain programs.

Sharing and reusing operation know-how

General-purpose templates for configuring subprocedures are provided as Exapilot standard tool. Common subprocedures, both standard and user-created ones, can be saved in the library and used repeatedly.

Graphics drawing function

Draws lines, circles, rectangles, and arrows on the Exapilot's workspace to create standard operation procedures (SOP).

Procedure flow printing function

Sets header/footer when printing the procedure flows. Printing of exceptional flow, subprocedures, and spare subprocedures are selectable.

Hierarchical arrangement of procedure modules

Procedure modules can be arranged hierarchically, up to 300 levels.

PCS tag existence-checking function

Verifies PCS tag existence and tag types while preparing for the commercial operation.

Note: Where there is no OPC server connected, the PCS tag-existence-checking function cannot be performed.

● Operation

On-line operation navigator

Displays the created workflow on a Exapilot client as an on-line operation navigator. By printing out the workflow, it is used as a standard operating procedures (SOP). Operation know-how can be shared among operators and it can be used for operators' training.

Debugging function

- Offline mode

Debugging of the created workflow can be done without a PCS, using input values preset in Exapilot. Output values are not transmitted to the PCS but kept within Exapilot.

- Trial mode

Input data from a PCS or other subprocedures, but not output to the PCS. The output values are kept within Exapilot.

This debugging function can be used as a training simulator on site by using online data but not disturbing the operations in action.

Message window component function

Exapilot's message windows can be displayed on the CENTUM graphic windows allowing operators to use Exapilot from the CENTUM display.

Event wait unit procedure function

Exapilot receives CENTUM's process alarm messages, sequence messages, and other alarms & events, which enables to create an application which is associated with the CENTUM.

Online maintenance function

Subprocedures can be modified without interrupting the main procedure operations or causing influence to the subprocedures which are not modified.

Dynamic message function

Descriptions of the messages can be modified while the PCS is in operation to make operators better understood the status.

Hyperlink function

Opens a document or launches a program specified in the subprocedure from the message window. Also opens a document or launches other programs hyperlinked to the text on the work space.

Dynamic generic name

Exchanging of the existing tag name with an arbitrary one is facilitated.

Operation comment input function

Operator can leave operation messages to engineers who created the operation procedure confirmation message dialogue window is displayed. This function enables to share the operational knowledge between operators and engineers so that those help improve the procedure logics.

● Utility

Security function

Operator authorities, access limits, or scope of work of each operator is defined.

For Exapilot, either one of the user authentication are selectable.

- Windows user authentication mode
User authentications can be defined by using Windows standard authentication logic.
- Exapilot user authentication mode
User authentications can be defined by using Exapilot specific logic.

Historical report function

- Message report
Outputs confirm, alarm, guidance, and error messages to a file in CSV format.
- Output history report
Outputs a history report that the process components data output in CSV file.

Audit trail function (supporting 21 CFR Part11)

Users are able to save operation histories such as start/stop procedures, output history, and Exapilot operating messages for the specified period. The historical information helps users analyze the operation processes.

Save/restore procedures function

Users are able to move the procedures from other PCs and back them up.

IT security support

IT security level can be selected from standard or legacy model depending on the system security requirements. Under the common security policy among Yokogawa products, Exapilot adopts the same level of IT security with the CENTUM systems.

● Procedure execution

Multiple OPC servers connecting function

Users are able to individually define which OPC server to be connected for each procedure.

OPC cache read

OPC server data read can be selected from device read or cache read. Cache read is suitable for reading a large volume of data such as advanced alarm because it suppresses the system device loading and enables monitoring the system while accumulating the data efficiently.

PCS output confirmation function (*1)

A dialogue window is displayed to let operators and engineers confirm the PCS output, which prevents erroneous output to PCS.

At the same time, this function further improves operation reliability by supporting the operation with confirmation.

- Note: Not all of the functions described here are available for the previous versions of the Exapilot.
- *1: Exapilot for HIS and Exapilot Office can be used during trial operation mode and offline operation mode are selected.

■ OPTIONAL PRODUCTS

Exapilot takes the optional functions as described in this section. Different options are available depending on the types of Exapilot licenses.

● Procedures expansion

The number of main procedures concurrently executed by Exapilot Professional and Exapilot Standard can be increased. The number of Exapilot clients can also be increased.

● Multi-run procedures expansion

By assigning different operation IDs, the identical main procedures can be executed simultaneously when launching the procedures. It enables to monitor the operation progress and semi-automate manual operations in simple processes such as batch that runs in one-way sequences.

Note: For more detail, Please contact Yokogawa.

● Additional advanced alarm function

Monitoring of equipment module failure, process failure, and operator misoperation during steady-state operation are enabled.

Note: Number of procedures is not increased even by adding this option. Exapilot for HIS already includes this function.

● MS-Excel link unit procedure

Data input/output to/from MS-Excel is supported.

Note: Microsoft Excel version 2007 or 2010 (32bit) is required.
The MS-Excel file format must be the following.

- Microsoft Excel book (*.xlsx)
- Excel Macro enabled workbook (*.xlsm)
- Excel Binary workbook (*.xlsb)
- Excel 97-2003 book (*.xls)
- Comma Separate Values file (*.csv)

● Exaquantum link unit procedure

Data input/output to/from Exaquantum, Yokogawa's plant information management system (PIMS) is supported.

Note: To use this function, Exaquantum client is required on the server where this function is installed.

● E-mail communication unit procedure

Users can send e-mails from Exapilot to a mail server. A connection between SMTP server and SSL can be established by specifying the SMTP authentication/port number for e-mail communication setting.

● ActiveX component

Consisting with following components, users are able to create their own operating screens on HIS graphic windows, MX-Excel, Visual Basic, and Exaquantum Explorer.

- Grid control
- Button indicator control for procedure/subprocedure run/stop
- Message component 2
- Correlation diagnosis component
- Trend component
- Chart component

Note: When Exapilot Active-X Component option is pasted to Microsoft Excel or Microsoft Visual Basic, the following versions are required.

- Microsoft Excel 2007/2010 (32bit)
- Microsoft Visual Studio 2005 (SP1)/ 2008(SP1)

● User VB script unit procedure

VB scripts created by users can be executed on Exapilot .

● MS-Excel add-in

Exapilot's data can be displayed on MS-Excel cells real time. This function is helpful when MS-Excel is used as an operation window.

Note: To use this function, Microsoft Excel is required. MS-Excel versions and file formats are the same as MS-Excel link unit procedure.

● Self-documentation

All the Exapilot's main procedure settings can be exported into Microsoft Word files and printed on papers. It helps debugging of the procedural flow charts, and the files can be used as standard operation procedure (SOP) and management documents.

Note: To use this option, Microsoft Word 2007 or 2010 (32bit) is required. When the self-documentation function is running the PC's CPU loading increases.

■ Exapilot basic

Item		Exapilot Basic				
		Professional	Standard	for HIS	Office	
Installation	No. of installation	1/PC				
	Installed destination PC	HIS (*1)	X (*2)	XX	XX (*3)	XX
		Exaopc-installed PC or general-purpose PC	XX		N/A	XX
Procedure Capacity and Restrictions	No. of procedures concurrently executable		4	1		
	No. of built main procedures		20	5		
	No. of Exapilot client (*4)		8	2		
	Max. No. of unit procedure (*5)	No. of unit procedures	10000/main procedure (*6)		1000/main procedure	
			1000/subprocedure			
		No. of unit subprocedures	300/main procedure			
		No. of unit procedures modules	1000/main procedure			
	Max. No. of variables	No. of registered procedures modules	1000 /PC			
		No. of PCS variables	5000/main procedure (*7)		1000/main procedure	5000/main procedure
		No. of Global variables	5000/main procedure			
	No. of Local variables	1000/subprocedure				
PCS Communication	Data read from PCS		XX		N/A	
	Data write to PCS		XX		N/A	
Exaopc Communication	Exaopc OPC Interface Package		XX		N/A	
	Exaopc OPC Interface Package for HIS		N/A	XX		N/A

XX: Available

X: Available; however, the client can only be installed

N/A: Not Available

*1: The Exaopc OPC interface package (for HIS) has to be prepared separately.

*2: Only Exapilot client can be installed when applying Exapilot Professional to the CENTUM HIS.

*3: The server and client packages of the 'Exapilot for HIS' cannot be installed on separate PCs.

*4: The total number of operation windows, builder windows, and utility windows to be connected simultaneously to the procedure server.

*5: Maximum number of the unit procedure is the sum of unit procedures and unit procedure for advanced alarm.

*6: In case the multi-run procedures expansion option is applied, the maximum number of unit procedure is 5000 per multi-run procedure.

*7: The Exapilot Standard can be connected to the Exaopc OPC interface package (for HIS) as one of the OPC clients; however, the total number of PCS variables becomes 1000 per main procedure, instead of 5000.

■ Exapilot Option

Exapilot options are available to Exapilot Standard and Exapilot Professionals only, and not for Exapilot Office.

Option		Exapilot			
		Professional	Standard	for HIS	Office
Exapilot basic option	Procedure expansion	XX (Max.: 3)	XX (Max.: 2)	N/A	N/A
	Multi-run procedures expansion	XX (Max.: 3)	XX (Max.: 3) (*1)	N/A	N/A
Exapilot option	Additional Advanced Alarm Function	XX	XX	X (*2)	N/A
	MS-Excel Link Unit Procedure	XX	XX	N/A	N/A
	Exaquantum Link Unit Procedure	XX	XX	N/A	N/A
	E-Mail Unit Procedure	XX	XX	N/A	N/A
	ActiveX Component	XX	XX	N/A	N/A
	User VB Script Unit Procedure	XX	XX	N/A	N/A
	MS-Excel Add-In	XX	XX	N/A	N/A
Self-documentation Option	XX	XX	N/A	N/A	

XX: Available

X: Available; however, the client can only be installed.

N/A: Not Available

Note: When 'XX' mark is shown in the column, the number of option that can be added to the package is one (1), unless otherwise the maximum number of options are shown.

*1: When Exapilot Standard resides with CENTUM HIS, the Multi-run procedures expansion option cannot be added.

*2: Exapilot for HIS includes the additional advanced alarm function. Other Exapilot Options cannot be added on to it.

When the procedures expansion option is applied, the maximum application capacity is as shown in the below table.

Basic License	No. of additional option	No. of procedures concurrently executable	No. of built main procedures built	No. of Exapilot client (*1)
Exapilot Standard	0 (No addition)	1	5	2
	1	2	10	4
	2	3	15	6
Exapilot Professional	0 (No addition)	4	20	8
	1	6	25	10
	2	8	30	12
	3	10	35	14

*1: Number of client means the number of procedures (displays) which can be connected to the operation server simultaneously. It does not represent the number of client PC. The number of displays is the sum of operation windows, configuration windows, and utility windows.

■ Configuration of Exapilot Engineering/Operation Client and Server

More than one Exapilot client can be simultaneously connected to one Exapilot server. Each of the builder window and operation window are collectively referred to as Exapilot client. For example, when the maximum number of clients is 4, Exapilot is able to perform 3 operation windows and one builder window.

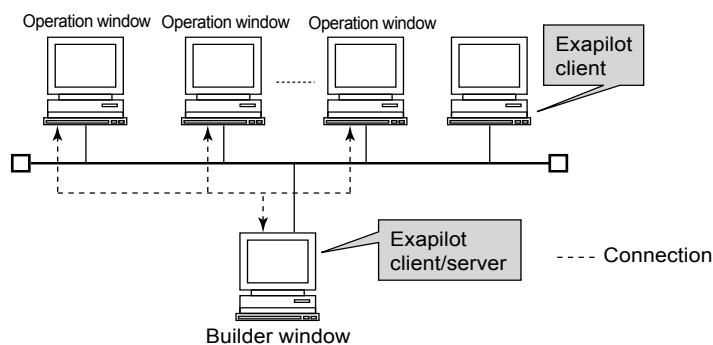

F07E.ai

■ SYSTEM CONFIGURATION

● Example of Connecting Exapilot Professional or Exapilot Standard with CENTUM VP

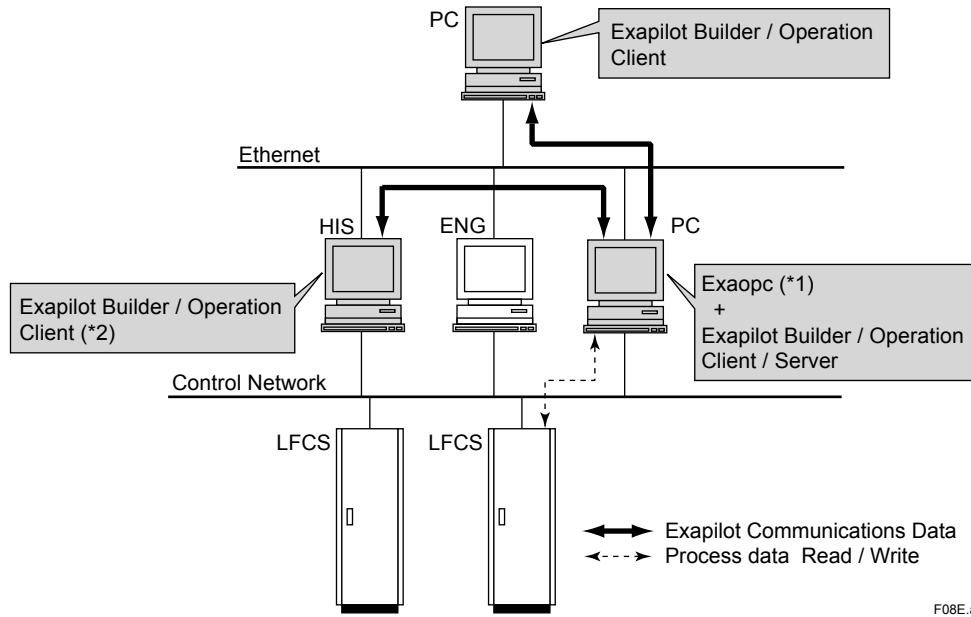

F08E.ai

*1: Refer to Exaopc OPC interface package general specifications (GS 36J02A10-01E) during the system configuration (engineering).

*2: Only Exapilot client can be installed when applying Exapilot Professional to the CENTUM HIS.

● Example of Coexisting Exapilot Standard or Exapilot for HIS with CENTUM VP HIS

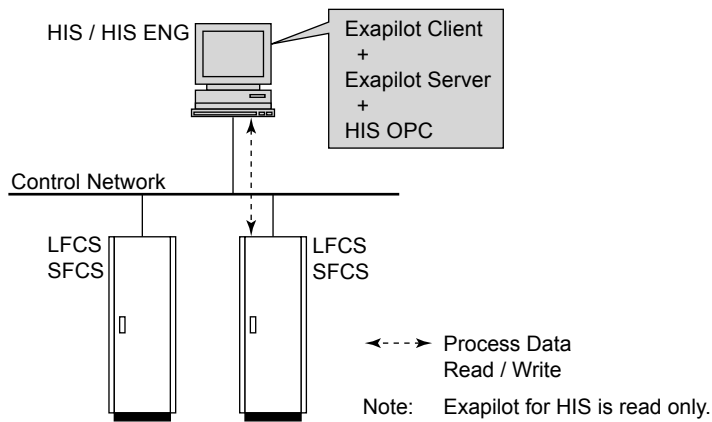

F10E.ai

● Example of Connection with CENTUM Integrated System

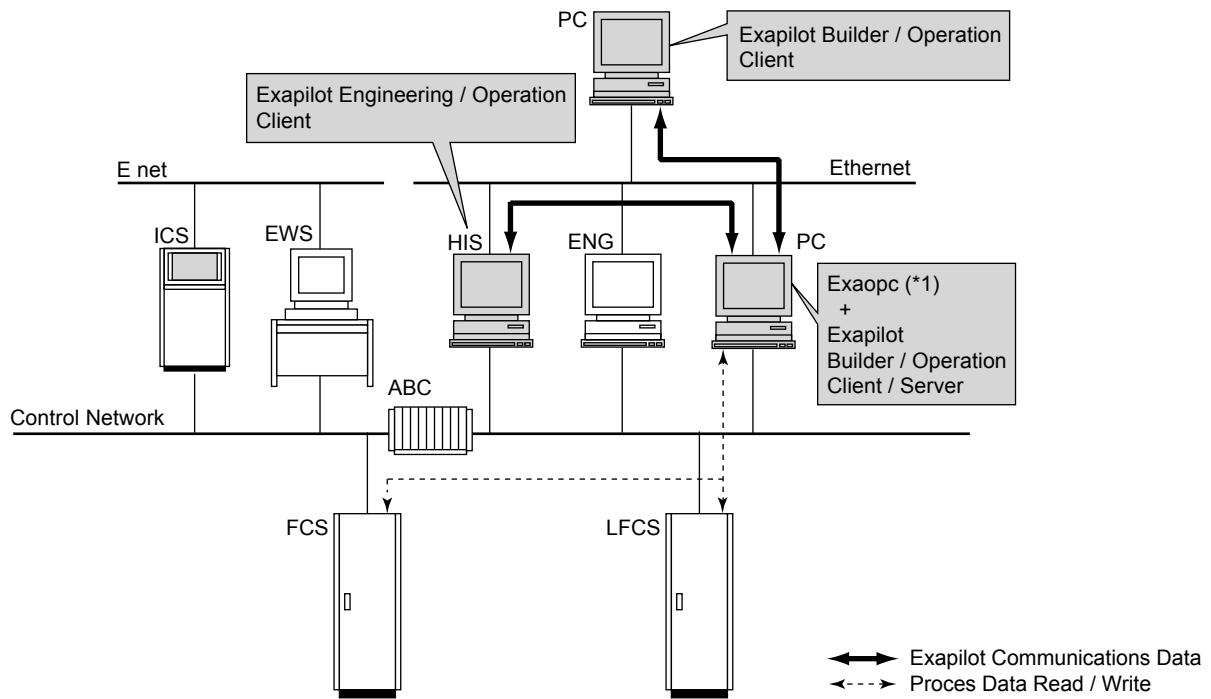

F09E.ai

*1: Refer to Exaopc OPC interface package general specifications (GS 36J02A10-01E) during the system configuration (engineering).

■ OPERATING ENVIRONMENT

● Hardware Operating Environment

PC for installing Exapilot Server and Client functions

Specification item	OS (Refer to software operating environment for more details.)	
	Windows Vista, Windows Server 2008	Windows 7, Windows Server 2008 R2
Machine	IBM PC/AT Compatible (DOS/V)	
CPU	Core 2 Duo Processor (X86) 2.66 GHz or faster	Core 2 Duo Processor (X64) 2.66 GHz or faster
Main memory	Required	1 GB or more (*1)
	Recommended	2 GB or more
Disk capacity	4 GB or more of disk space must be available (In case Exapilot coexists with HIS, 4 GB or more of disk capacity is required in HIS area)	
Color	32768 colors or more	
Resolution	1024 × 768 or higher	
Sound	Recommended (For message output)	

Note: When Exapilot resides with HIS, follow the hardware operating environment for HIS.

*1: Windows 7 requires 2 GB or more.

● Software Operating Environment

Exapilot Server

Windows OS	Service Pack
Windows Vista Business (32-bit)	2
Windows Server 2008 Standard (32-bit)	2
Windows 7 Professional (64-bit)	1
Windows Server 2008 R2 Standard (64-bit)	1

Exapilot Client

Windows OS	Service Pack
Windows Vista Business (32-bit)	2
Windows Server 2008 Standard (32-bit)	2
Windows 7 Professional (32-bit)	1
Windows 7 Professional (64-bit)	1
Windows Server 2008 R2 Standard (64-bit)	1

Note: Visual Studio 2005 (Service Pack 1) or 2008 (Service Pack 1) is required for developing user functions.

Documnet Brower

Adobe Reader 9.5, 10.1 or later

Note: It is required to install Adobe Reader to read Exapilot electronic documents.

● Coexistence and connectivity among Exapilot and other solution-based software packages (SBP)

The definitions of the words “coexistence” and “connectivity” are as described below.

Coexistence: When Exapilot and other solution-based software packages are installed on the same PC.

Connectivity: When Exapilot is connected with Exaopc or HIS OPC via a network.

Note: Solution-based software packages refer to Exaopc, Exaquantum, Exaquantum/Batch, Exaplog, Exasmoc and Exarqe packages.

● Operating environment of Exapilot in combination with OPC interface package

- Exapilot connects with Exaopc OPC interface package R3.10 or later.
- Exapilot connects with Exaopc OPC interface package (for HIS) R3.05 or later.
- The revision number of the Exaopc client to be connected with Exaopc server must be identical.

Note: Refer to GS 36J02A10-01E (NTPF100 Exaopc OPC interface package) for more details.

● **Limitations in coexistence with other SBP products**

The applicable combination of a server and client(s) for Exapilot and other SBP products is as shown below. Use the latest release numbers of SBP products at the release of Exapilot R3.90.

Other SBP Products \ Exapilot	Server	Client
Server	Case1	Case1
Client	Case1	Case2

The combination of SBP Products that can coexist with Exapilot is as show below.

Case1:

	Exaopc (R3.71)	Exaquantum (R2.70)	Exaquantum/Batch	Exaplog (R3.40)	Exasmoc	Exarqe
Exapilot (R3.95)	OK	OK (*1)	N/A	OK	N/A	N/A

Case2:

	Exaopc (R3.71)	Exaquantum (R2.70)	Exaquantum/Batch	Exaplog (R3.40)	Exasmoc (R4.03)	Exarqe (R4.03)
Exapilot (R3.95)	OK	OK (*1)	N/A	OK	OK	OK

Note: Please make sure the model and version of the packages and the compatibility of operating system environment.

*1: Apply the legacy model for Exapilot's IT security.

● **Limitations in coexistence with HIS**

Exapilot (R3.90)	CENTUM VP HIS	Remarks
Server/Client	R4.01 or later	Exapilot for HIS, Exapilot Standard
Client only	R4.01 or later	Only the client of Exapilot Standard or Exapilot Professional can be installed in HIS environment

Note: Please check not only the model and version of the package but also the compatibility of operating system environment.

■ **Annual Maintenance Contract**

The product is supplied without the manufacturer's warranty costs. Users are required to enter into an annual maintenance contract to receive maintenance service from the first year of the purchase onward. For more details of the maintenance service, please refer to 'Maintenance Services for Solution-based Software Package' (GS 36J20A10-01E).

■ MODEL AND SUFFIX CODE

Exapilot Operation Efficiency Improvement Package

		Description
Model	NTPS200	Exapilot Operation Efficiency Improvement Package
Suffix Codes	-S	Basic Software License (with media)
	1	For Exapilot Professional
	2	For Exapilot Standard
	3	For Exapilot for HIS (*1)
	4	For Exapilot Office (*2)
Option Codes	1	English version
	/□-A10	For Exapilot Procedures Expansion (□: required quantity)
	/□-A20	For Exapilot Multi-run Procedures Expansion (□: required quantity)
	/1-A30	For Exapilot Additional Advanced Alarm Function
	/1-B10	For Exapilot MS-Excel Link Unit Procedure
	/1-B30	For Exapilot Exaquantum Link Unit Procedure
	/1-B50	For Exapilot E-Mail Unit Procedure
	/1-B60	For Exapilot ActiveX Component
	/1-B70	For Exapilot User VB Script Unit Procedure
	/1-B80	For Exapilot MS-Excel Add-In
/1-B91	For Exapilot Self-documentation Option	

Note: The Exapilot Office can be upgraded to Exapilot for HIS, Exapilot Standard, or Exapilot Professional.

The Exapilot for HIS can be upgraded to Exapilot Standard or Exapilot Professional.

The Exapilot Standard can be upgraded to Exapilot Professional.

*1: NTPS200-S31 doesn't have a function to output data to FCS. And any option can not be added to NTPS200-S31.

*2: NTPS200-S41 doesn't have a function to communicate with external. And any option can not be added to NTPS200-S41.

Maintenance Service for Exapilot

		Description
Model	NTMS200	Maintenance Service for Exapilot
Suffix Codes	-S	Annual Contract
	1	For Exapilot Professional
	2	For Exapilot Standard
	3	For Exapilot for HIS
	A	For separate purchase of standalone 'Option Codes' below
Option Codes	1	Always 1
	/□-A10	For Exapilot Procedures Expansion (□: required quantity)
	/□-A20	For Exapilot Multi-run Procedures Expansion (□: required quantity)
	/1-A30	For Exapilot Additional Advanced Alarm Function

Note: Exapilot Office is not subjected to the maintenance contract, however, inquiries are accepted for the first 90 days from the date of delivery via the following URL:

<http://www.yokogawa.com/sbs/sbs-index.htm>

■ ORDERING INFORMATION

Specify model and suffix codes.

■ TRADEMARK

- Exapilot, Exaopc, Exaquantum, Exaplog, Exasmoc and Exarqe are registered trademark of Yokogawa Electric Corporation.
- CENTUM is a registered trademark of Yokogawa Electric Corporation.
- Windows, Excel, Word, Visual Basic and Visual Studio are registered trademark of Microsoft Corporation in the United States and /or other countries.
- Ethernet is a registered trademark of XEROX Corporation.
- Core 2 Duo are registered trademark of Intel Corporation.
- Adobe Reader is either registered trademarks or trademarks of Adobe Systems Incorporated in the United States and/or other countries.
- All other company and product names in this GS are registered trademarks or trademarks of respective companies.