

General Specifications

NTPS100 Exaplog Event Analysis Package



GS 36J06A10-01E

■ GENERAL

The Exaplog Event Analysis Package is designed to provide managers, engineers and supervising operators with tools to analyze the historical plant operation record file of a DCS, so that the production process can be improved. It can generate trend graphs for quantitative analysis, as well as pie charts and tables for analyzing distributions and classifying events. It can help you eliminate unnecessary alarms, improve inefficient operation sequences, and thus improve production processes.

■ FUNCTIONAL SPECIFICATIONS

This package consists of three functions – PLView, PLSummary, and PLAdmin:

- PLView: This is a GUI interface for interactive analysis.
- PLSummary (Long Term Summary Tool): Provides a visual image of event tendencies occurred in a long term in graphs.
- PLAdmin: This is used to administer the “adapter” and “server”. With the “adapter” event data is transmitted from the DCS historical file to the “server” periodically, or manually. The “server” saves them in a database and provides analytical functions.

● Features

Event Balance Trend (EBT) Graph

This displays the balance between “process request volume” and “operator work volume.” The process request volume means the number of events that the operator should respond to such as process alarms, annunciator messages and operator guide messages. The operator work volume means the amount of work that the operator has manipulated such as tag entries and tag mode changes.

3W (“When, What, Where”) Filter

This extracts events occurring at problem areas. By identifying events using 3W (When, What, Where) attributes; When = time stamp of an event, What = event category (kind), and Where = physical ID (tag name, station No., etc.), and combining the EBT graph, 2W1H (Why, Who, How) can be estimated.

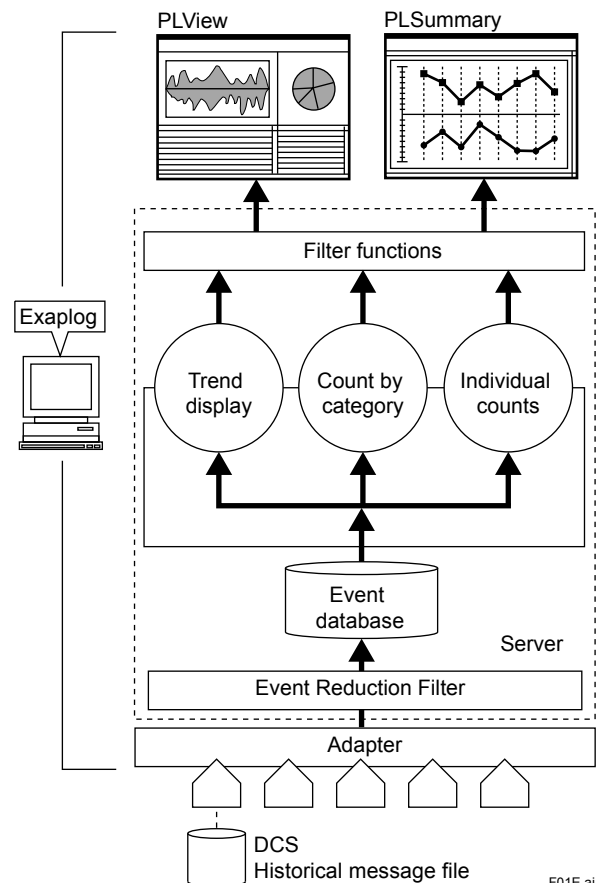

Event Reduction Filter

This function filters out events and saves only events required for analysis into the Exaplog database.

● **PLView (Event Analysis Tool)**

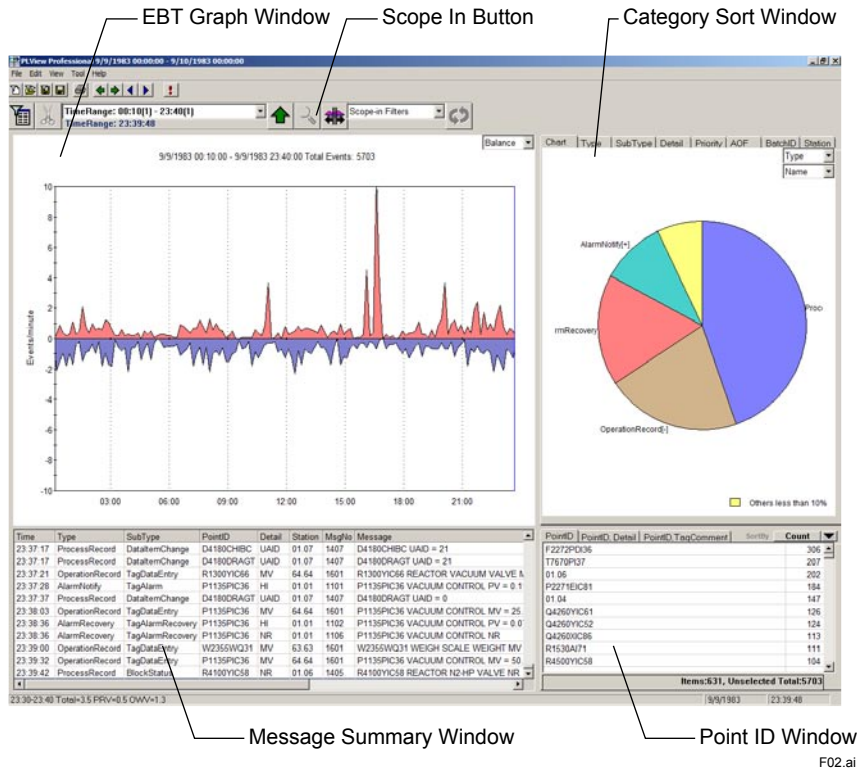

EBT Graph Window (upper left)

This window displays the rate of event occurrences for maximum one month, which is the number of events occurring over a ten-minute time span divided by ten (minutes). You can display only the total number of events on the positive axis; or the total number of process requests on the positive axis and the total number of operations on the negative axis. When you click a point on the time axis, ten events which occurred at the selected time span are displayed in a table (lower left). The Scope-In function allows you to zoom in on a selected time span, and update EBT graphs and other window information accordingly.

Message Summary Window (lower left)

The time of an event, its type, and event detail are displayed in order of event occurrences.

Category Sort Window (upper right)

Events are sorted by type (such as alarm notification or recovery) and displayed in a pie chart or table.

Point ID Sort Window (lower right)

Event IDs such as tag names are displayed in order of the number of event occurrences or in ascending/descending order.

Event Data Filtering

Scope-In: Allows you to display only a selected event, or zoom in on a selected time span.

Filter-out: Allows you to delete a selected event from the display.

● PLSummary (Long Term Summary Tool)

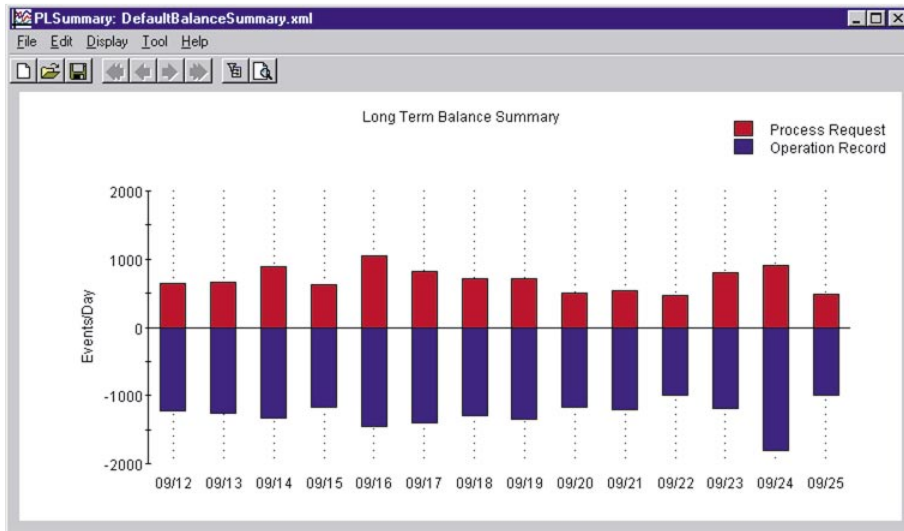

F07E.ai

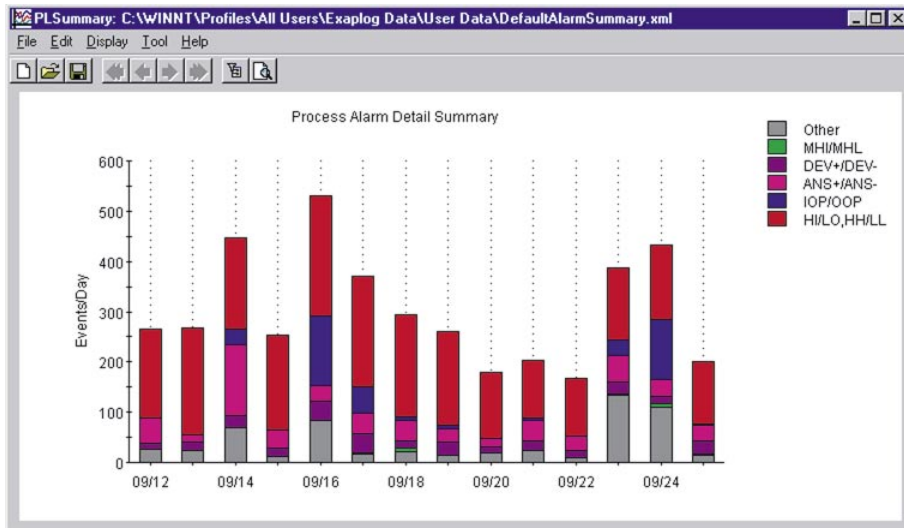

F08E.ai

PLSummary is a tool to sum up events and to show event tendencies occurred in a long term. Counts the number of events defined by the filter in PLView per day and displays in graphs.

- Summary items: Up to 10 filters / summary file
- Summary days: Up to 366 days / summary file
- Display scale: 7 days, 14 days, or 31 days

■ SUPPORTED PLATFORMS

Exaplog R3.30 or later supports the following platforms.

- CENTUM VP: R4.01 or later
- CENTUM CS 3000: R2.01 or later (*1)
- CENTUM CS 1000: R1.01 or later (*1)
- CENTUM CS: R2.05 or later (*2)
- CENTUM-XL: R12 or later
- μXL: R11 or later
- Exaquantum: R2.20 or later
- TDCS3000 for Honeywell
- Delta-V for Emerson

- *1: Alarm Priority is supported by R2.05 or later.
Alarm suppression (AOF) is supported by R2.06 or later.
- *2: In case you use the Enhanced Security Package, please let us know.

■ ACQUISITION PERIOD

CENTUM VP, CENTUM CS 3000/CS 1000, CENTUM CS, Exaquantum: 1 hour, 3 hours, 5 hours, 8 hours, 12 hours, 1 day, or manual.

CENTUM-XL, μXL: Acquires printout data from Operator Station via RS-232C Cable for Exaplog CENTUM-XL/μXL Adapter (Model KB51) (when Exaplog server operating)

■ OPERATING ENVIRONMENT

● Hardware Operating Environment (Required Specification)

IBM PC/AT (DOS/V) Compatible

CPU: Pentium III 800 MHz or faster (Windows XP, Server 2003)
Core 2 Duo 2.13GHz or faster (Windows Vista, Windows Server 2008)

Main Memory: 256 MB or more (Windows XP, Windows Server 2003)
1 GB or more (Windows Vista, Windows Server 2008)

Disk Capacity: 50 MB or more free space (*1)
Resolution: 1024 x 768 or more recommended (Minimum 800 x 600)

● Hardware Operating Environment (Recommended Specification)

IBM PC/AT (DOS/V) Compatible

CPU: Pentium 4 1.8GHz or faster (Windows XP, Windows Server 2003)
Core 2 Duo 2.13GHz or faster (Windows Vista, Windows Server 2008)

Main Memory: 768 MB or more (Windows XP, Windows Server 2003)
1 GB or more (Windows Vista, Windows Server 2008)

Disk Capacity: 50 MB or more free space (*1)
Resolution: 1024 x 768 or more recommended (Minimum 800 x 600)

Note: When number of event exceeds 100,000/month, the following hardware operating environment

CPU: Pentium 4 3GHz or faster
Main Memory: 2 GB or more

*1: Exaplog annually requires about 800MB of database capacity for 10,000 events/day. Please prepare sufficient disc space. (R3.20 or later version supports the automatic datafile delete function.) Please periodically backup data to external media. Be careful not to have insufficient disc space in data file folder.

● Software Operating Environment

OS: Microsoft Windows Server 2003 (*1)

Windows Server 2003 Standard Edition + Service Pack 1, 2
Windows Server 2003 R2 Standard Edition + Service Pack 1, 2

OS: Microsoft Windows Server 2008

Windows Server 2008 Standard Edition + Service Pack 2

OS: Microsoft Windows XP Professional

Windows XP Professional + Service Pack 1, 2 (No guarantee of proper operation for Windows XP Home Edition)

OS: Microsoft Windows Vista

Windows Vista Business Edition + Service Pack 1, 2

*1: Do not use as domain controller server
Note: Supporting the above OS for 32 bit only.

● Document Browser

Adobe Reader 8.0 or later

Note: It is necessary to install Adobe Reader to read document of Exaopc.

● Support for IT Security

Several security models (legacy, Standard, and Strengthened types) will be available, so that users will be able to select the security level to match their requirements. (Supported by R3.30 or later)

CENTUM VP and CENTUM CS 3000/CS 1000 platforms are supported.

● Limitation for coexistence with HIS

Exaplog	HIS
Server	Not Limited
Client	Not Limited

● **Limitation for coexistence of Exa packages**

Other Exa Packages(*1)	Server	Client
Exaplog		
Server	Case1	Case1
Client	Case1	Case2

*1: Exaopc, Exaquantum, Exaquantum/Batch, Exapilot, Exasmoc and Exarqe

Case1: The combination of Exa packages that can coexist with Exaplog is as show below.

	Exaopc	Exaquantum	Exaquantum /Batch	Exapilot	Exasmoc	Exarqe
Exaplog	OK	OK	N/A	OK	N/A	N/A

N/A: Not Applicable

Note: Exaplog adopts "Legacy model" for its IT security. The combination of the latest revision of those Exa packages with Exaplog has passed the coexistence test criteria as of this GS issuance date.

Case2: The model of the IT security for both Exaplog and other Exa packages clients must be identical. Please pay attention to the installation procedure in case of installing clients of Exasmoc or Exarqe with Exapilot client simultaneously on the "Standard" or "Strengthened" model of IT security. The combination of the latest revision of those Exa packages with Exaplog has passed the coexistence test criteria as of this GS issuance date. For more information, please contact Yokogawa.

● **CENTUM VP HIS (Universal PC)**

Main Memory: 2 GB or more
CENTUM VP: R4.01 or later

● **CENTUM CS 3000/CS 1000 HIS (universal PC)**

Main Memory: 256 MB or more
CENTUM CS 3000: R3.03 or later
CENTUM CS 1000: R3.03 or later

SYSTEM CONFIGURATION

Server PC: installed full function of Exaplog such as PLAdmin, PLView and PLSummary.

Client PC: installed client function of Exaplog such as PLView and PLSummary.

CENTUM VP, CS 3000/CS 1000

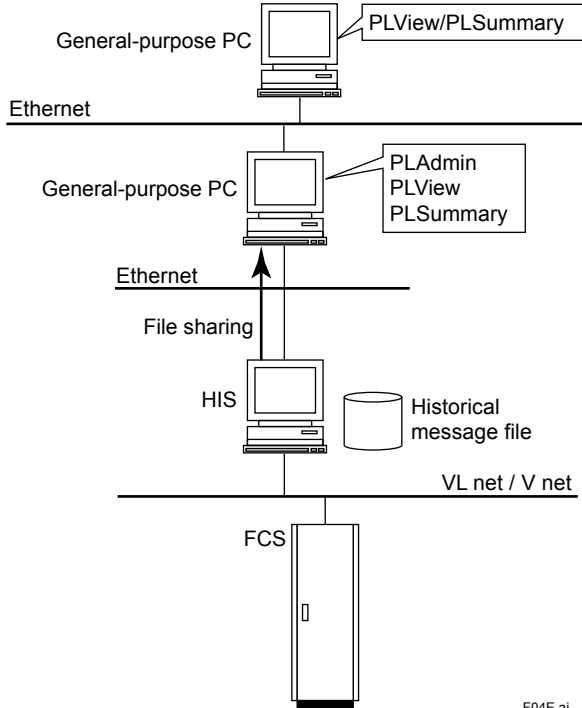

F04E.ai

Figure: CENTUM VP, CS 3000/CS 1000 Connection Example

Exaplog Installed in HIS

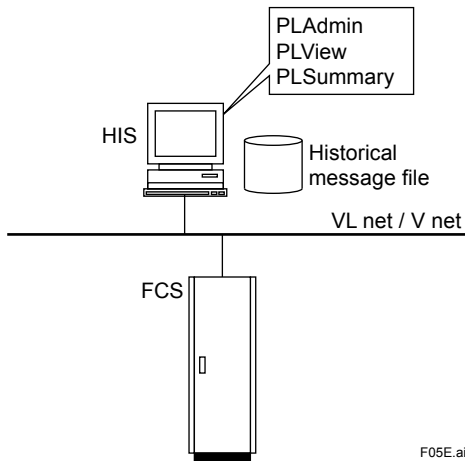

F05E.ai

Figure: Exaplog Installed in HIS (General-purpose PC) (R3)

*1: It is recommended to store an Exaplog event database in a drive other than system drives for CENTUM VP and CS 3000/CS 1000.

CENTUM CS

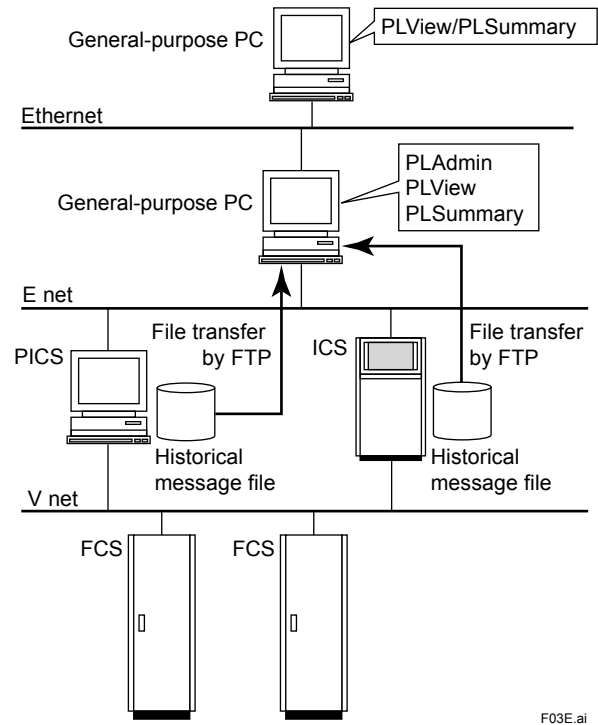

F03E.ai

Figure: CENTUM CS Connection Example

CENTUM-XL

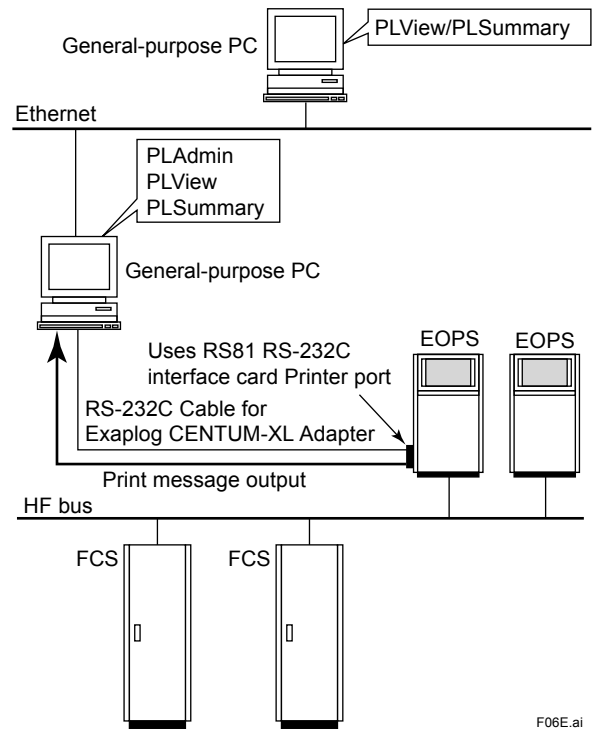

F06E.ai

Figure: CENTUM-XL Connection Example

- *1: To connect the CENTUM-XL, an RS-232C Cable for Exaplog CENTUM-XL Adapter (model: KB51) is required.
- *2: EOPS output ports to Exaplog is restricted by Operator station-control station grouping for CENTUM-XL.

μXL

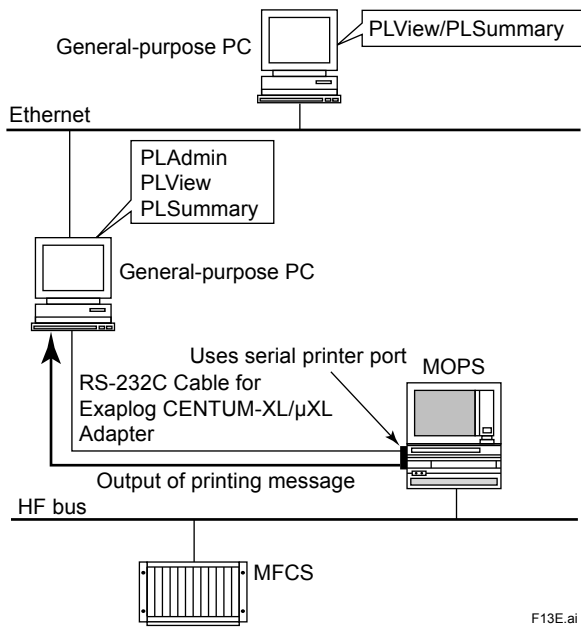

Figure: μXL Connection Example

*1: RS-232C Cable for Exaplog CENTUM-XL/μXL Adapter (model: KB51) is required.

● With Exaquantum

For reading Exaquantum event data, Exaplog needs following operation environment.

- Exaplog installed PC needs Exaquantum Explorer Client Package (NTPP002).

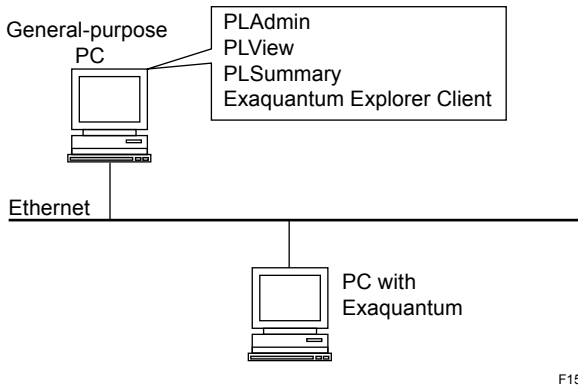

Figure: Exaquantum Connection Example

Note: It is possible to read Alarm & Events (A&E) data from the Exaquantum that are gathered from CENTUM VP, CENTUM CS 3000/CS 1000, CENTUM CS and CENTUM-XL via Exaopc. The A&E data of Exaquantum gathered via OPC server redundancy functions (Exaopc-RD (NTPF100-SX)) is not supported.

■ APPLICATION CAPACITY

● Maximum number of event storage

About 150,000 data/day

● Event Database Capacity (for 10,000 events/day)

About 2.1MB/day
About 800MB/year

● Maximum number of events displayed

1,000,000 data/month

● Number of Client PC Connected

Maximum number of Client PC Connected: 4 units/server PC

● Number of Screens

Note: Number of screens are the total of PLView screens and PLSummary screens
Maximum number of screens displayed: 8 screens/server PC
Maximum number of screens displayed: 4 screens/client PC

Example) Maximum number of screens displayed when maximum system is configured (Server PC: 1, client PC: 4)

$$24 \text{ screens} = 8 \text{ screens} \times 1 + 4 \text{ screens} \times 4$$

● Number of Connected Systems

8 control system/server (Exaplog Professional)
1 control system/server (Exaplog Standard)

■ PRODUCT LINEUP

● Exaplog Professional

Up to eight types of system can be registered for being analyzed. (The connectable types of system are specified by the DCS type of the adapter). Up to eight adapters can be registered. Each adapter gathers data with its own gathering cycle. However, event data is gathered simultaneously.

● Exaplog Standard

Only one type of system can be registered for being analyzed. (The connectable type of system is specified by the DCS type of the adapter). Up to eight adapters can be registered. Each adapter gathers data with its own gathering cycle. However, event data is gathered simultaneously.

To classify saved event data, please register only one adapter in Exaplog Standard to gather and save data per system or project.

One system is defined as the DCS, SCADA system, and so on that generate events, or Exaquantum event data.

One project is defined as follows:

- CENTUM VP, CS 3000: Project defined by the Engineering Function
- CENTUM CS 1000: Domain
- CENTUM CS: Project defined by the Engineering Function

When there are multiple targets in one project you want to analyze, it is recommended that you use one package for each. For large CENTUM Systems, there are often several "plants" in a single project. Here "plant" means independent process units controlled by different operators, and one project is defined as one system consisting of multiple plants. When you try to analyze such project by one package, all the events from several plants are mixed in a database. You can analyze event data by plant by filtering it, but it is much more efficient to use one package per plant.

■ MODEL AND SUFFIX CODES

		Description
Model	NTPS100	Exaplog Event Analysis Package
Suffix Codes	-S	Software license (including media)
	1	Exaplog Professional (Connectable type of system: 8 types)
	2	Exaplog Standard (Connectable type of system: 1 type)
	1	English version

- *1: Annual maintenance contract is required.
- *2: For specification details of RS-232C Cable for Exaplog CENTUM-XL/μXL Adapter (Model KB51), see GS 36J10A20-01E.

■ ORDERING INFORMATION

Specify model and suffix codes.

■ TRADEMARKS

- CENTUM is a registered trademark of Yokogawa Electric Corporation.
- Exaplog and Exaquantum are trademarks of Yokogawa Electric Corporation.
- Windows is a registered trademark of Microsoft Corporation in the United States and/or other countries.
- Ethernet is a registered trademark of XEROX Corporation.
- Adobe Reader is either registered trademarks or trademarks of Adobe Systems Incorporated in the United States and/or other countries.
- Other company names and product names in this GS are registered trademarks or trademarks of respective companies.