

General Specifications

NTPS100
Exaplog Event Analysis Package



GS 36J06A10-01E

■ GENERAL

The Exaplog Event Analysis Package is designed to provide managers, engineers and supervising operators with tools to analyze the historical plant operation record file of a process control system (PCS), so that the production process can be improved. It can generate trend graphs for quantitative analysis, as well as pie charts and tables for analyzing distributions and classifying events. It can help you eliminate unnecessary alarms, improve inefficient operation sequences, and thus improve production processes.

■ FUNCTIONAL SPECIFICATIONS

This package consists of three functions – PLView, PLSummary, and PLAdmin:

- PLView: This is a GUI interface for interactive analysis.
- PLSummary (Long Term Summary Tool): Provides a visual image of event tendencies occurred in a long term in graphs.
- PLAdmin: This is used to administer the “adapter” and “server”. With the “adapter” event data is transmitted from the PCS historical file to the “server” periodically, or manually. The “server” saves them in a database and provides analytical functions.

● Features

Event Balance Trend (EBT) Graph

This displays the balance between “process request volume” and “operator work volume.” The process request volume means the number of events that the operator should respond to such as process alarms, annunciator messages and operator guide messages. The operator work volume means the amount of work that the operator has manipulated such as tag entries and tag mode changes.

3W (“When, What, Where”) Filter

This extracts events occurring at problem areas. By identifying events using 3W (When, What, Where) attributes; When = time stamp of an event, What = event category (kind), and Where = physical ID (tag name, station No., etc.), and combining the EBT graph, 2W1H (Why, Who, How) can be estimated.

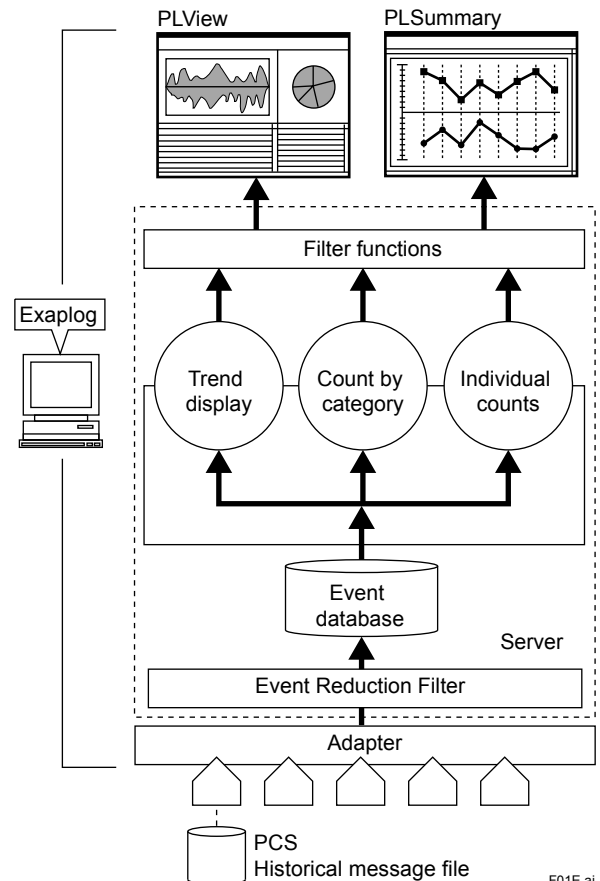

Event Reduction Filter

This function filters out events and saves only events required for analysis into the Exaplog database.

● **PLView (Event Analysis Tool)**

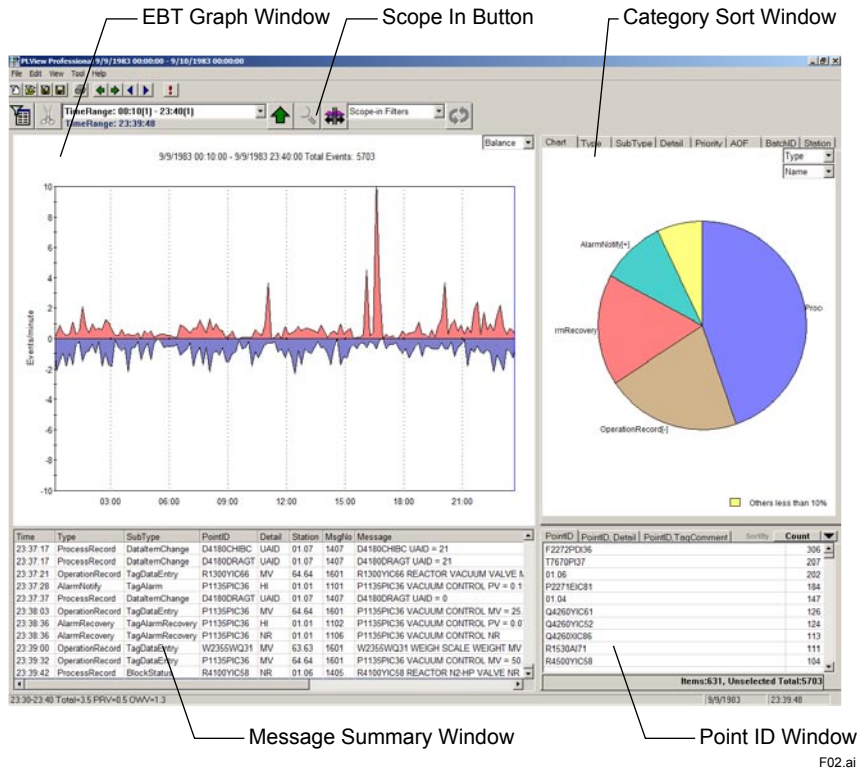

EBT Graph Window (upper left)

This window displays the rate of event occurrences for maximum one month, which is the number of events occurring over a ten-minute time span divided by ten (minutes). You can display only the total number of events on the positive axis; or the total number of process requests on the positive axis and the total number of operations on the negative axis. When you click a point on the time axis, ten events which occurred at the selected time span are displayed in a table (lower left). The Scope-In function allows you to zoom in on a selected time span, and update EBT graphs and other window information accordingly.

Message Summary Window (lower left)

The time of an event, its type, and event detail are displayed in order of event occurrences.

Category Sort Window (upper right)

Events are sorted by type (such as alarm notification or recovery) and displayed in a pie chart or table.

Point ID Sort Window (lower right)

Event IDs such as tag names are displayed in order of the number of event occurrences or in ascending/descending order.

Event Data Filtering

Scope-In: Allows you to display only a selected event, or zoom in on a selected time span.

Filter-out: Allows you to delete a selected event from the display.

● **PLSummary (Long Term Summary Tool)**

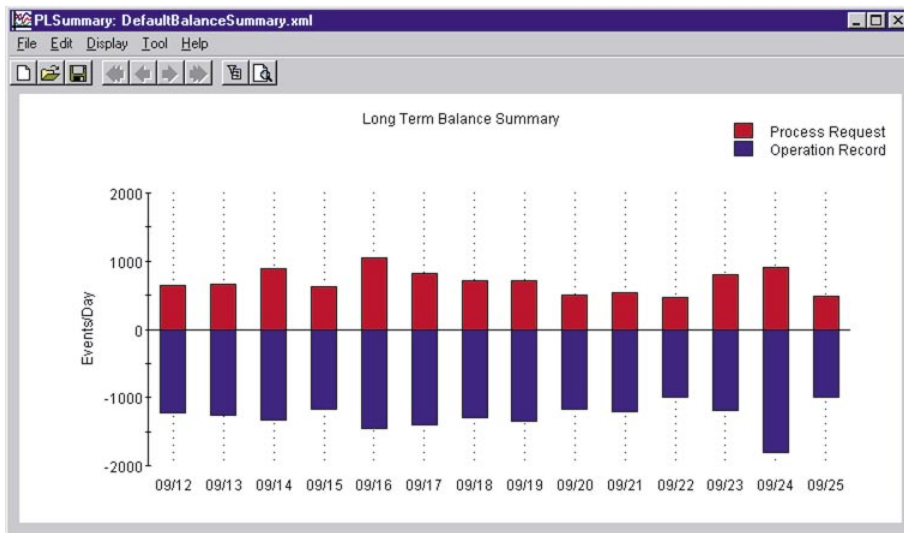

F07E.ai

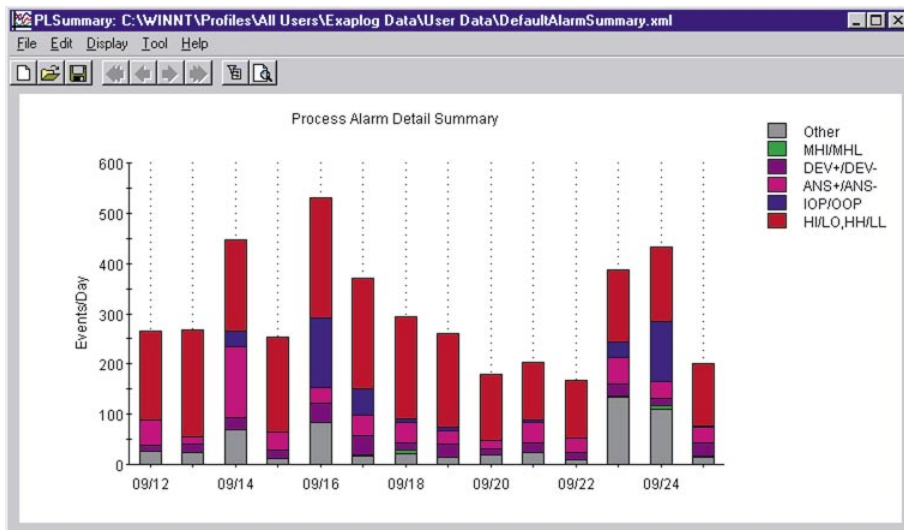

F08E.ai

PLSummary is a tool to sum up events and to show event tendencies occurred in a long term. Counts the number of events defined by the filter in PLView per day and displays in graphs.

- Summary items: Up to 10 filters / summary file
- Summary days: Up to 366 days / summary file
- Display scale: 7 days, 14 days, or 31 days

■ **SUPPORTED PLATFORMS**

Exaplog supports the following platforms.

- CENTUM VP: R4.01 or later
- CENTUM CS 3000: R2.01 or later (*1)
- CENTUM CS 1000: R1.01 or later (*1)
- CENTUM CS: R2.05 or later (*2)
- Exaquantum: R2.20 or later

Note: Please contact Yokogawa when connecting Exaplog with other platforms.

- *1: Alarm Priority is supported by R2.05 or later.
Alarm suppression (AOF) is supported by R2.06 or later.
- *2: In case you use the Enhanced Security Package, please let us know.

■ ACQUISITION PERIOD

CENTUM VP, CENTUM CS 3000/CS 1000, CENTUM CS, Exaquantum:
1 hour, 3 hours, 5 hours, 8 hours, 12 hours, 1 day, or manual.

■ OPERATING ENVIRONMENT

● Hardware Operating Environment

IBM PC/AT(DOS/V)Compatible

CPU: Core 2 Duo 2.13 GHz or faster
Main Memory: 1 GB or more (Required specification) (*1)
2 GB or more (Recommended specification)
Disk Capacity: 50 MB or more of free space required. (*2)
Resolution: 1024 × 768 or higher is recommended. (Minimum 800 × 600)

*1: Windows 7 requires 2 GB or more.

*2: Exaplog annually requires about 800 MB of database capacity for 10000 events/day. Please provide sufficient disc spaces. (R3.20 or later version supports the automatic data file delete function.) Please backup data periodically to external media and avoid running out of disc spaces in the data file folder.

● Software Operating Environment

OS: Microsoft Windows Server 2008

Windows Server 2008 Standard Edition + Service Pack 2
Windows Server 2008 R2 Standard Edition + Service Pack 1

OS: Microsoft Windows 7

Windows 7 Professional + Service Pack 1

OS: Microsoft Windows Vista

Windows Vista Business Edition + Service Pack 2
Note: All the above OS are English version only.
Note: Windows Server 2008 R2 and Windows 7 support only 64-bit, and

● Document Browser

Adobe Reader 9.4 or 10.1 later is required.

Note: An installation of Adobe Reader is required for reading Exaplog's document.

● IT Security support

Legacy and standard types of security models are available to let users select the required security level.

● Limitations on coexistence with Solution-based software packages (SBP)

In case one or more SBP products (*1) and the Exaplog resides in a single PC, it is called “coexistent.”

The applicable combination of a server and client(s) for Exaplog and other SBP products is as shown below. Use the latest release numbers of SBP products at the release of Exaplog R3.40.

*1: Exaopc, Exaquantum, Exaquantum/Batch, Exapilot, Exasmoc, and Exarqe

Exaplog \ Other SBP Products	Server	Client
Server	Case1	Case1
Client	Case1	Case2

The combination of SBP Products that can coexist with Exaplog is as show below.

Case1

	Exaopc (R3.70)	Exaquantum (R2.60)	Exaquantum /Batch	Exapilot (R3.90)	Exasmoc	Exarqe
Exaplog (R3.40)	OK	OK(*2)	N/A	OK	N/A	N/A

OK: Applicable N/A: Not Applicable

Case2

	Exaopc (R3.70)	Exaquantum (R2.60)	Exaquantum /Batch	Exapilot (R3.90)	Exasmoc (R4.02)	Exarqe (R4.02)
Exaplog (R3.40)	OK	OK(*2)	N/A	OK	OK(*2)	OK(*2)

OK: Applicable N/A: Not Applicable

Note: Please make sure the model and version of the packages and the compatibility of operating system environment.

*2: Apply the legacy model for Exaplog’s IT security.

● Limitations on coexistence with CENTUM HIS(Human Interface Station)

In case CENTUM HIS (universal PC) and the Exaplog resides in a single PC, it is called “coexistent.” Exaplog can be coexistent with the following CENTUM HIS.

Exaplog (R3.40)	CENTUM VP HIS
Server	R4.01 or later
Client	R4.01 or later

Note: IT security model of Exaplog and CENTUM HIS must be identical.
Please contact Yokogawa when Exaplog resides with other HIS platforms.

SYSTEM CONFIGURATION

Server PC: installed full function of Exaplog such as PLAdmin, PLView and PLSummary.
 Client PC: installed client function of Exaplog such as PLView and PLSummary.

CENTUM VP, CS 3000/CS 1000

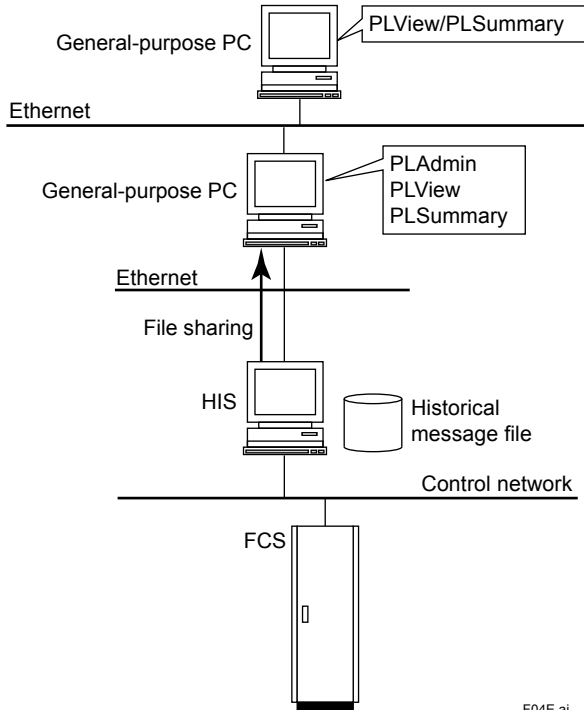

Figure: CENTUM VP, CS 3000/CS 1000 Connection Example

F04E.ai

Exaplog Installed in HIS

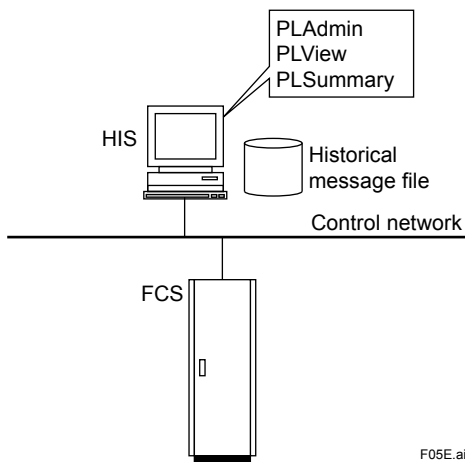
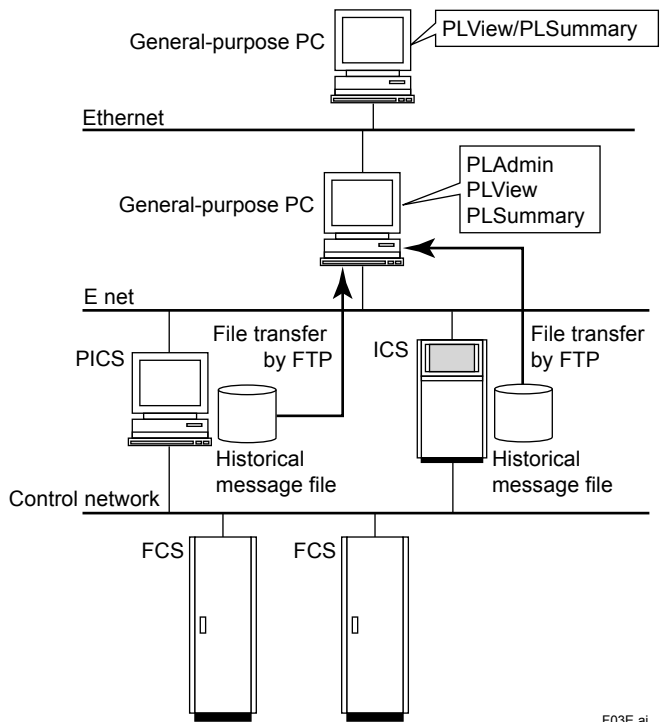

Figure: Exaplog Installed in HIS (General-purpose PC)

F05E.ai

*1: It is recommended to store an Exaplog event database in a drive other than system drives for CENTUM VP.

CENTUM CS



F03E.ai

Figure: CENTUM CS Connection Example

With Exaquantum

For reading Exaquantum event data, Exaplog needs following operation environment.

- Exaplog server PC needs Exaquantum Explorer Client Package (NTPP002).

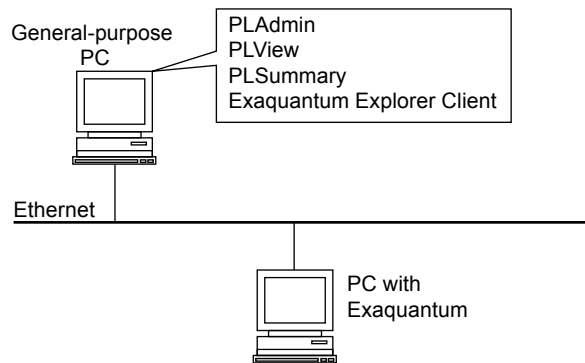

F15.ai

Figure: Exaquantum Connection Example

Note: It is possible to read Alarm & Events (A&E) data from the Exaquantum that are gathered from CENTUM VP, CENTUM CS 3000/CS 1000, and CENTUM CS via Exaopc. The A&E data of Exaquantum gathered via OPC server redundancy functions (Exaopc-RD (NTPF100-SX)) is not supported.

■ APPLICATION CAPACITY

● Maximum number of event storage

About 150,000 data/day

● Event Database Capacity (for 10,000 events/day)

About 2.1MB/day

About 800MB/year

● Maximum number of events displayed

1,000,000 data/month

● Number of Client PC Connected

Maximum number of Client PC Connected: 4 units/
server PC

● Number of Screens

Note: Number of screens are the total of PLView
screens and PLSummary screens

Maximum number of screens displayed: 8
screens/server PC

Maximum number of screens displayed: 4
screens/client PC

Example) Maximum number of screens displayed
when maximum system is configured (Server PC:
1, client PC: 4)

$24 \text{ screens} = 8 \text{ screens} \times 1 + 4 \text{ screens} \times 4$

● Number of Connected Systems

8 control system/server (Exaplog Professional)

1 control system/server (Exaplog Standard)

■ PRODUCT LINEUP

● Exaplog Professional

Up to eight types of system can be registered for being analyzed. (The connectable types of system are specified by the DCS type of the adapter). Up to eight adapters can be registered. Each adapter gathers data with its own gathering cycle. However, event data is gathered simultaneously.

● Exaplog Standard

Only one type of system can be registered for being analyzed. (The connectable type of system is specified by the DCS type of the adapter). Up to eight adapters can be registered. Each adapter gathers data with its own gathering cycle. However, event data is gathered simultaneously.

To classify saved event data, please register only one adapter in Exaplog Standard to gather and save data per system or project.

One system is defined as the DCS, SCADA system, and so on that generate events, or Exaquantum event data.

One project is defined as follows:

CENTUM VP, CS 3000: Project defined by the
Engineering Function

CENTUM CS 1000: Domain

CENTUM CS: Project defined by the Engineering
Function

When there are multiple targets in one project you want to analyze, it is recommended that you use one package for each. For large CENTUM Systems, there are often several "plants" in a single project. Here "plant" means independent process units controlled by different operators, and one project is defined as one system consisting of multiple plants. When you try to analyze such project by one package, all the events from several plants are mixed in a database. You can analyze event data by plant by filtering it, but it is much more efficient to use one package per plant.

■ ANNUAL MAINTENANCE CONTRACT

The product is supplied without the manufacturer's warranty costs. Users are required to enter into an annual maintenance contract to receive maintenance service from the first year of the purchase onward. For more details of the maintenance service, please refer to 'Maintenance Services for Solution-Based Software Package' [GS 36J02A10-01E].

■ MODEL AND SUFFIX CODES

Exaplog Event Analysis Package

		Description
Model	NTPS100	Exaplog Event Analysis Package
Suffix Codes	-S	Basic software license (with media)
	1	Exaplog Professional (Connectable types of system: 8 Types)
	2	Exaplog Standard (Connectable types of system: 1 Type)
	1	English version

Maintenance Service for Exaplog

		Description
Model	NTMS100	Maintenance Service for Exaplog
Suffix Codes	-S	Annual Contract
	1	For Exaplog Professional
	2	For Exaplog Standard
	1	Always 1

■ ORDERING INFORMATION

Specify model and suffix codes.

■ TRADEMARKS

- CENTUM is a registered trademark of Yokogawa Electric Corporation.
- Exaplog, Exaopc, Exaquantum, Exasmoc, and Exarqe are trademarks of Yokogawa Electric Corporation.
- Windows is a registered trademark of Microsoft Corporation in the United States and/or other countries.
- Ethernet is a registered trademark of XEROX Corporation.
- Adobe Reader is either registered trademarks or trademarks of Adobe Systems Incorporated in the United States and/or other countries.
- Other company names and product names in this GS are registered trademarks or trademarks of respective companies.